

# MASON-MERCER

## EXPANSION COMPENSATORS & HOUSED EXPANSION JOINTS

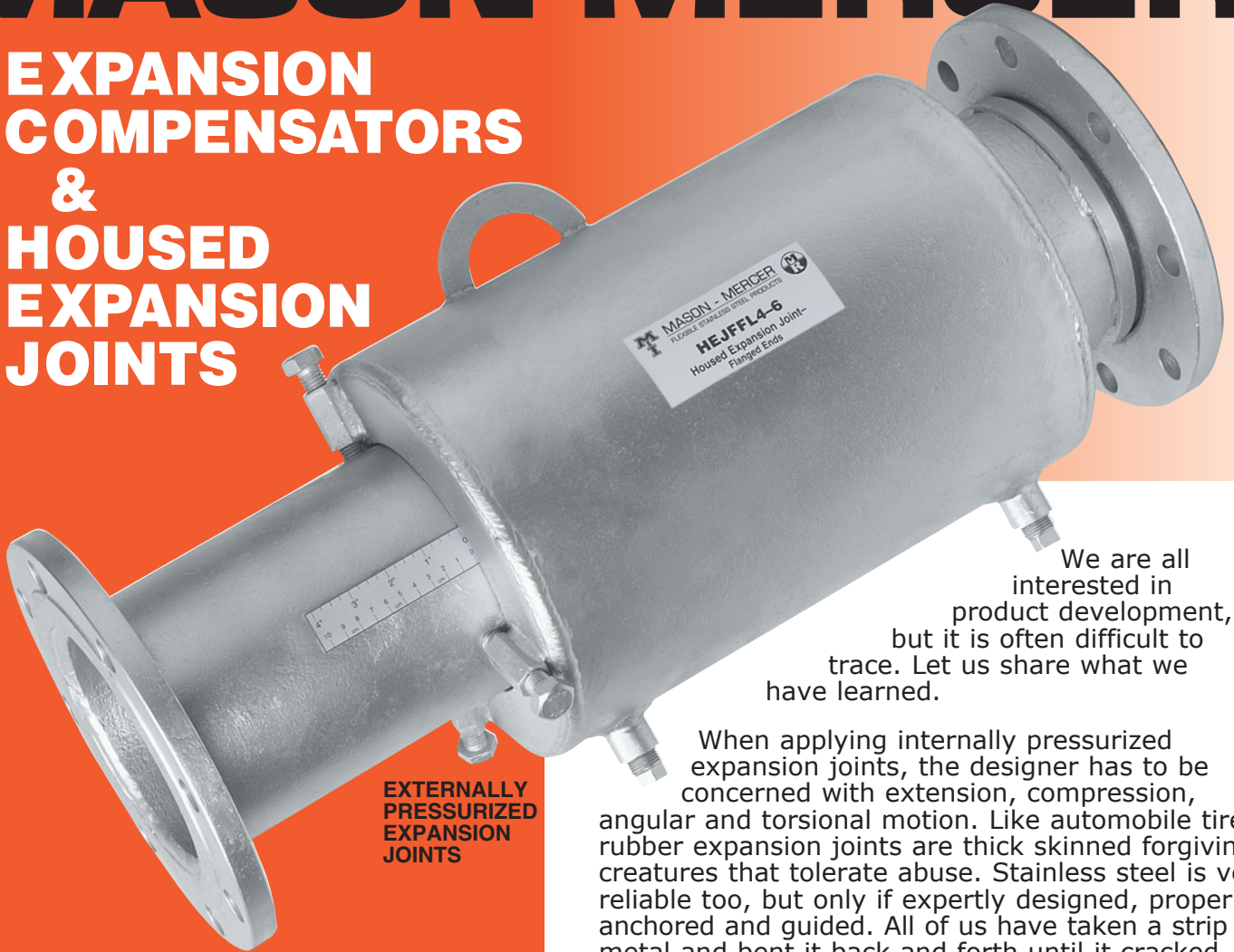

EXTERNALLY  
PRESSURIZED  
EXPANSION  
JOINTS

We are all interested in product development, but it is often difficult to trace. Let us share what we have learned.

When applying internally pressurized expansion joints, the designer has to be concerned with extension, compression, angular and torsional motion. Like automobile tires, rubber expansion joints are thick skinned forgiving creatures that tolerate abuse. Stainless steel is very reliable too, but only if expertly designed, properly anchored and guided. All of us have taken a strip of metal and bent it back and forth until it cracked and snapped. Multiple corrugations designed to low stresses eliminate the problem.

INTERNALLY  
PRESSURIZED  
EXPANSION  
JOINTS



An anchor close to an expansion joint stabilizes one side. Then two guides, one 4 diameters from the joint and the other a minimum of 14 diameters from the first, lead the piping straight in and out. If the anchors are both up and down-stream, four guides are required, two on each side. Improper anchoring or guiding leads to failure. If major movements are required, it may become necessary to increase the outside diameter to prevent buckling. This increases both thrust and cost.

There is always the worry of personal injury from hot liquid or steam, even though the evolution from steel to galvanized steel, copper, bronze and finally stainless steel, has increased service life and operating pressures.

Some designer tried to solve some of these internally pressurized problems by telescoping two square housings around the joint. It reduced the rotational problem, but without the two external guides, the possibility of angular failure is always there.

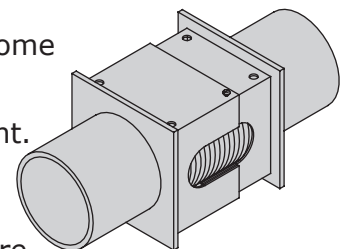

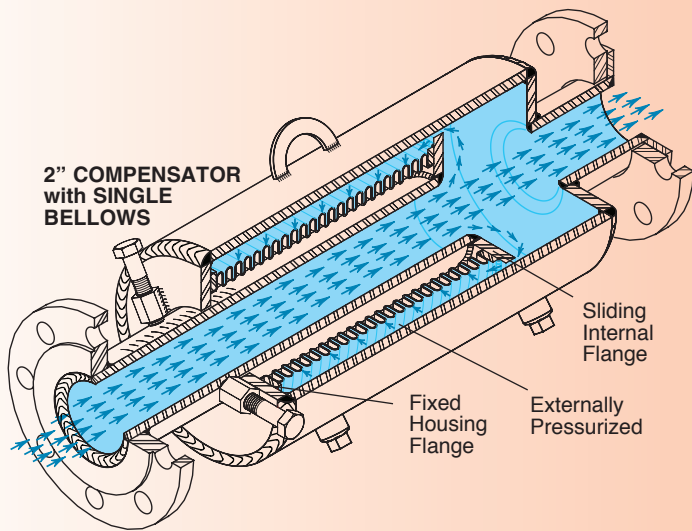

Oddly enough, some people still describe the 2" movement Expansion Compensators as internally pressurized. They are not. Only the old design on page 1 is internally pressurized.

We had no illusions about coming up with a very different approach, but it is never our way to introduce a product without improvement. So just as we did with the straight hoses and Vees, we purchased twenty or thirty compensators and housed expansion joints from various manufacturers to see what was going on.

Perhaps the original engineer designed a whole range of consistent products. However, the more samples we looked at, the more confusing it became. There was no consistency. When people copy products to cheapen them or never completely understand the original design, the copy often suffers.

Virtually all manufacturers advertise 2" movement multi-ply bellows. Many companies just buy and resell without writing specs or testing. When their suppliers deliver single ply, the resale company would not know. There is no great harm, as the only reason to go to multiple plies is to increase pressure ratings without using a single thicker wall. A single thickness with the same corrugations and movements would suffer higher stresses, a shorter service life and the bellows would have a higher spring rate even though low spring rates are relatively unimportant. To maintain the same service life, the bellows would have to be longer to reduce movement per corrugation, and in addition to space considerations, more costly designs to manufacture.

Moving on to 4" and 8", most manufacturers use 2 ply, and some 3. The number is not particularly important. However, with greater movement, it becomes more difficult to maintain stability. Any stretched bellows is stable. However, pipelines do not only expand, they must cool and contract. When the motion is reversed and the bellows compressed, it can become unstable and buckle. Most manufacturers design to the maximum stable length and weld them to guide rings between sections to prevent buckling of a longer column.

Our own designs vary from product to product, just depending on what works best. Since people like to know what they are buying, we note the number of bellows and plies for all products at this writing. Most companies do not.

We found that to prevent buckling, some manufacturers had their bellows rubbing against the inside pipe or the outer shell. It would seem they must wear through and leak earlier, so tight fits are a poor way to go. (See bronze bellows photo on page 3)

Some years later there was a major change in concept. The industry turned to a completely housed construction. In this design, the bellows is welded to a sliding flange on the end of the piping, and to the fixed flange where the moving pipe enters. Unlike the old design, the fluid or gas surrounds the bellows so it is "Externally Pressurized". The design manuals say that a bellows is more stable when externally pressurized, but we have found no satisfactory explanation.

Self guiding is provided by the pipe passing through the opening on the one end and the small clearance of the moving flange inside the outer housing. Should there be a bellows failure, the escape is only through the lower clearance, and back along the pipe rather than in an unpredictable direction. The housing is a great safety feature, particularly in steam lines.

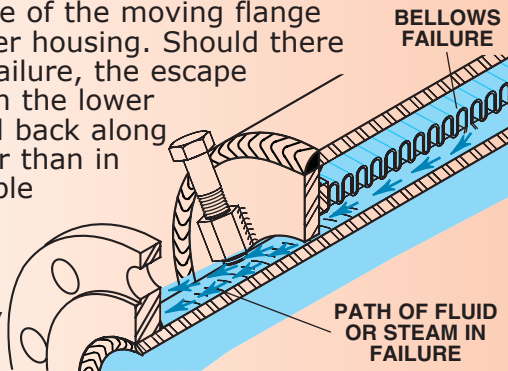

For whatever reason, the entire industry refers to 2" movement designs as Expansion Compensators. They are shipped preset to allow for inward travel only in hot lines. Should there be a dual temperature situation, there is no engineering reason the compensator cannot be moved in 3/4" before installation, so it would accommodate 1 1/4" pipe expansion and 3/4" contraction or some other setting.

When the rated inward motion is increased to 4" or more, the industry name changes to Housed Expansion Joints, which is a much better description. "Expansion Compensator" is a function, not a product.

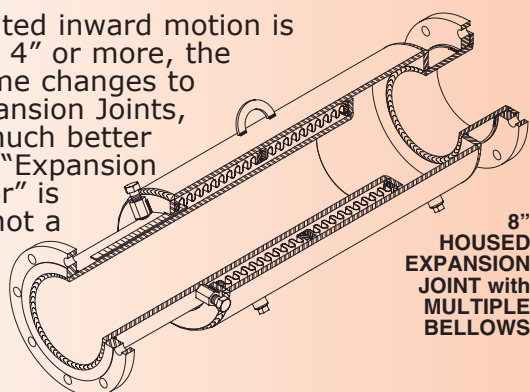

Others went to huge outer housings as compared to the inner pipe, so their products were clumsy (below). In our own designs, we have succeeded in providing good working clearances, both between the inside of the bellows and the moving pipe as well as the outer shell. We note clearances on all product drawings. Competitors do not. (See pages 6 through 11)



In checking spring rates, we found that some competitors are so concerned with alignment, that clearances between the moving pipe and the entry collar as well as the moving inner flange, and the outer shell were so tight that binding was a serious problem. We are publishing a few test curves to show this condition. Since there is no need for so small a tolerance, our clearances are roomier for smoother travel, as shown by the Mason test curve at the top of the next column. When expansion joints bind, it increases the anchorage loads. Binding intermediate rings stretch bellows unevenly and can cause failure.

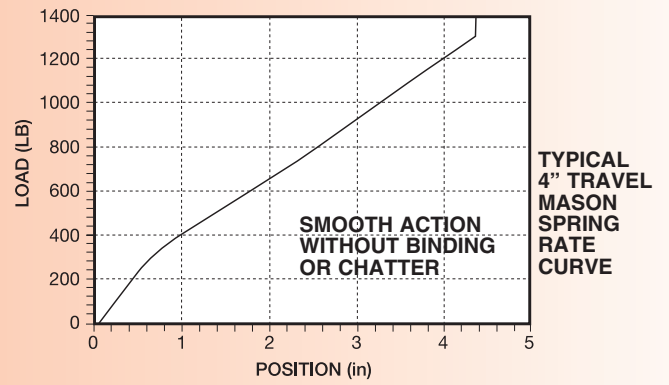
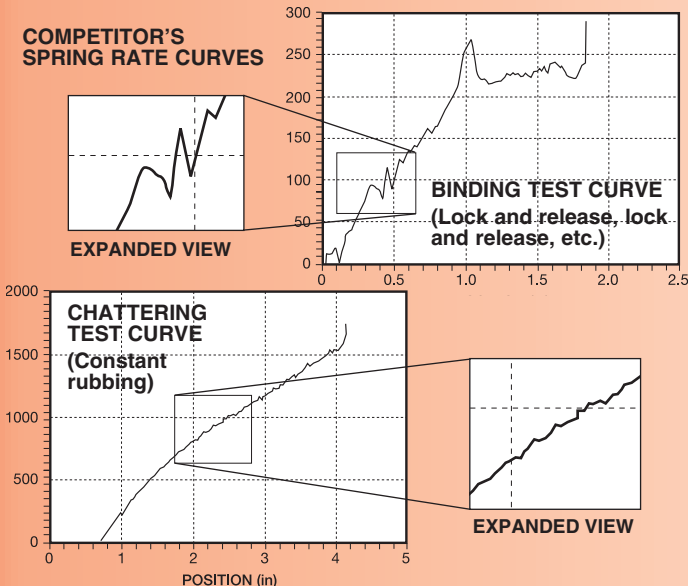

Another improvement is our introducing locking bolts to maintain the installed position. All of the other manufacturers use welded tabs. The tabs are knocked out after the piping is fixed to the expansion joint. Sometimes they are flimsy and fall off. More importantly, the side welds are often within the movement of the pipe entering the housing. The weld has to tear its way through until it clears. Not the smooth motion we would all like to have.

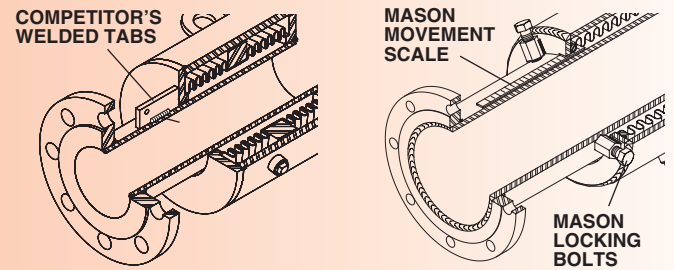

Perhaps our most interesting contribution is the introduction of a scale to confirm the starting position is zero for the average installation. Many of the stop-tapped samples we checked were not. When the joint is in service, the scale indicates how much the pipe has expanded and how much the bellows have been extended. In a hot and cold situation, you can loosen the restraining bolts, and push the bellows to the desired starting position to allow for a line cooling down or a seasonal change in temperature. Reading the scale makes it easy. Re-lock the bolts and continue with the installation. (Note: the 2" movement expansion compensators have a 0, 1" and 2" reference only.)

If for whatever reason you have to remove an expansion joint temporarily, you can retighten the locking bolts, remove it, do the maintenance work and reinstall the expansion joint without fighting it into position as you would have to with any other device. Loosen the bolts and it is back in service. Welded tabs would have been long gone. While any good mechanic can find a way, this is much easier.

Shortly after we sold our first housed expansion joints, we had a serious failure even before they were put into service. One of our contractors was prefabbing as much as possible to minimize time on the jobsite. Rather than installing the housed expansion joint between pipe ends in the field, he welded long extensions to the pipe on both

sides. In normal rough handling, one of the modified joints was dropped. The cantilever of the long welded pipe snapped the flange off the fixed end. When we got it back in the shop, we found the method we were using in machining the flange to the I.D. of the housing left a small lip around the pipe perimeter as sketched. This undersized weld looked great and would have held the pressure, but not impact.

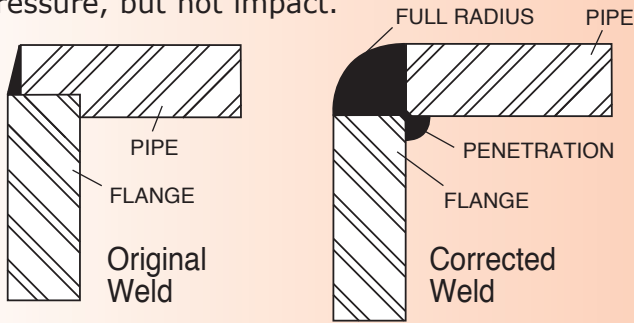

Here again, we checked competitor's products, and found our original technique was typical. We re-examined all of our welds and changed every one to good piping practice with welds as sketched. Maybe this is overkill, but neither you nor we will ever suffer a weld failure again and that's good to know.

Earlier we suggested the bellows spring rate was insignificant. The reason is the thrust from a housed expansion joint is equal to the area as calculated to about the center of the bellows multiplied by the pressure in the pipe line. Typically a 4" pipe bellows might have a 6 1/4" diameter to the center of the corrugation. At 225 psi the thrust force is a nominal 6900 lbs. The spring rate of our 4" travel HEJ is 300 lbs. per inch. The 8" HEJ is 150 lbs. per inch. Therefore, with either joint the total bellows resistance at 4" or 8" travel is 1200 lbs. This increases the anchor load to 6900 plus 1200 lbs. or 8100 lbs. total.  $1200/8100 = 15\%$ . If a competitive product were half as stiff, the anchorage requirement would drop to 7500 lbs. If twice as stiff, it would increase to 9300 lbs. In the real world, when designing an anchor, all these numbers are in the same order of magnitude. The spring force is relatively insignificant, except for an extremely unusual installation where there might be concern for buckling of copper pipe or something of that nature.

**SAFETY FACTOR**

Our last worry was the question of safety factor.

A flexible hose or internally pressurized expansion joint fails because the walls fail in tension beyond a given pressure. Since all housed expansion joints are pressurized externally, that is not the phenomena. The pressure on the outside eventually forces the

corrugations to squirm and become distorted until they collapse completely, as shown by one of our test photographs.

According to the standards established by The Stainless Steel Expansion Joint Institute, an expansion joint is considered safe when this collapse occurs at 2.25 times the working pressure. That means the safety factor is only 2.25. Most manufacturers do not publish their collapse ratios, but a 2.25 safety factor seemed very low. Braided hoses have safety factors between 3 and 4. Why is 2.25 acceptable in an expansion joint?

Flexible products are always riskier than solid pipe, so it seemed only right that our housed expansion joints and expansion compensators should have a **safety factor** between **3.5** and **4** as published and what we have worked to in all designs.

All expansion joints are more subject to collapse, when fully extended. Our ratings are all at full extension. In many cases the collapse may take place without leakage. However, when the pipe system cools down and the cycle reverses, the collapsed area is crushed and dramatic leakage follows. Should it turn out our spring rates are higher than some of our competitors, it is because of our safer bellows construction. Safety is far more important than spring rate.

We have an elaborate test facility to test Mercer Rubber Expansion Joints and all Stainless Steel products. All product designs are thoroughly tested before marketing. Unfortunately, our tests show design ratings by competitors are often optimistic. Testing rather than theoretical design is the only answer.

**Spring Rate Test in Progress**



**Competitor Pressure Failures**





### Hydro Pressure Test in Progress

If you have never had a problem with an expansion compensator or housed expansion joint, everything we have discussed may seem unimportant. However, our improvements will keep both of us out of trouble and make life easier. Let's review.

### Mason Improvements

1. Good operating clearances to prevent binding.
2. A much better locking mechanism that can be used to partially compress joints prior to installation to allow for contraction as well as expansion on installations with temperatures below ambient when in service. The locking device is a permanent part of the construction. They can always be tightened to hold the expansion joint in a particular position for removal while piping is serviced.
3. A depth gauge on the moving end to monitor movements, make certain that joints are at the 0 position before installation, or used to pre-set joints in some preferred position.
4. Great attention to canister and pipe welding details.
5. Internal and external clearances to prevent bellows wear because of rubbing.
6. Safety factors between 3.5 and 4, compared to others at 2.25. Double drains on most

designs, generous lifting near the center of gravity for easier handling.

7. A raised face flange and a floating flange on all flanged products for easier installation and bellows anti-torquing protection.
8. Grooved fittings are beveled as well to allow welding into pipe lines as an alternate method. (Mason does not recommend welding.)
9. Our staff of in-house engineers holding licenses in virtually all of the States with the capability to design or review complete piping systems when our clients need those services. We will try to help you in any case should you have bought from others that offer no engineering service. Seismic problems can be addressed as well.

**If the following tables of externally pressurized stock items do not meet all of your requirements, please let us offer custom product. We also manufacture internally pressurized products and welcome inquiries on these as well. We are here to help.**

**Thanks for bearing with me.**

Norman J. Mason, President

Bellows are externally pressurized.  
3.5 Minimum Safety Factor for both  
Bellows and Housing.

Vacuum Rating is 30 in (762mm) Hg

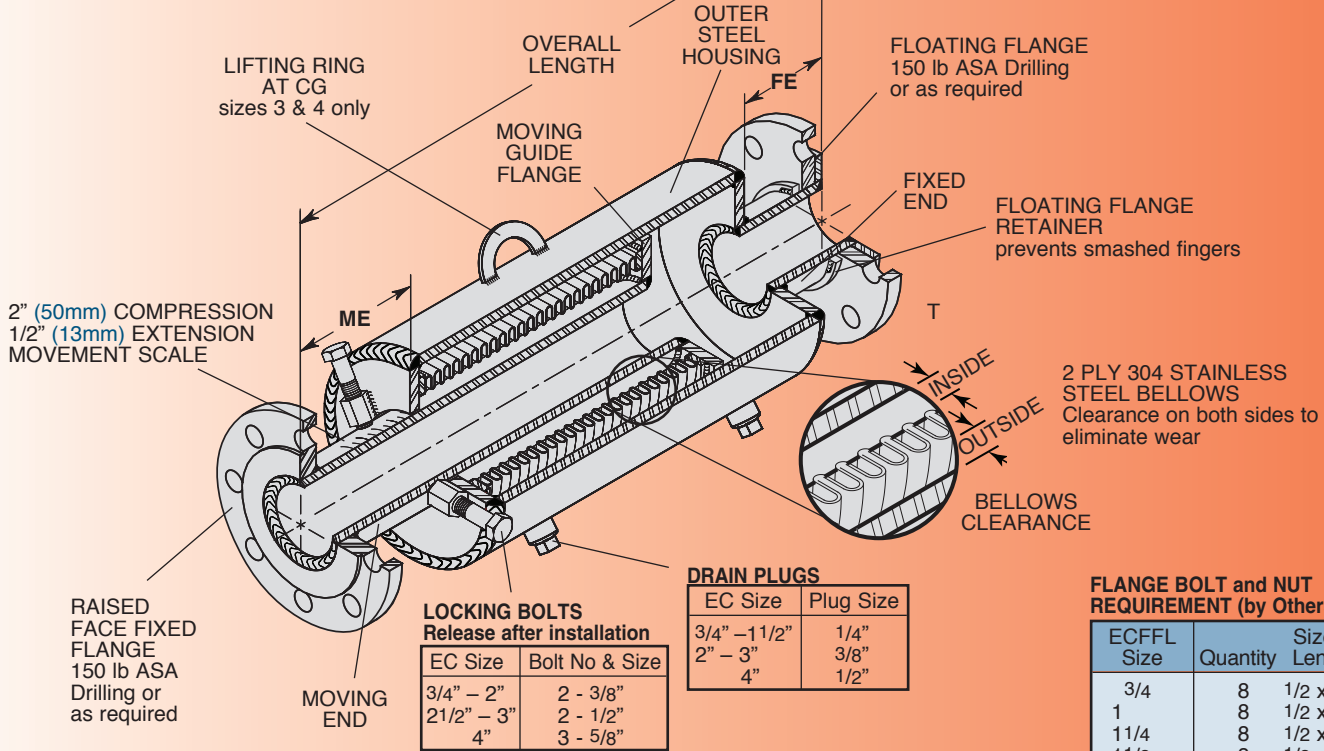

**LOCKING BOLTS**  
Release after installation

EC Size	Bolt No & Size
3/4" - 2"	2 - 3/8"
2 1/2" - 3"	2 - 1/2"
4"	3 - 5/8"

**DRAIN PLUGS**

EC Size	Plug Size
3/4" - 1 1/2"	1/4"
2" - 3"	3/8"
4"	1/2"

**FLANGE BOLT and NUT REQUIREMENT (by Others)**

ECFFL Size	Quantity	Size & Length
3/4	8	1/2 x 2 1/2
1	8	1/2 x 2 1/2
1 1/4	8	1/2 x 2 1/2
1 1/2	8	1/2 x 2 3/4
2 & 2 1/2	8	5/8 x 3
3	8	5/8 x 3 1/4
4	16	5/8 x 3 1/4

**CARBON STEEL PLATE FLANGE THICKNESS**

Pipe Size (in)	Flange Thickness T (in)	Flange Thickness T (mm)
3/4 thru 4	20 thru 100	5/8 16

**PRESSURE REDUCTION TABLE**

Temperature (°F)	Temperature (°C)	Rated Pressure (psi)	Rated Pressure (kg/cm²)
200	93	182	12.8
250	121	176	12.4
300	149	170	12.0
400	204	156	11.0
500	260	154	10.8
600	316	142	10.7
700	371	148	10.4
800	427	Not Recommended	

**INSERT FLANGE BOLTS AS SHOWN**



HEAD AT FIXED FLANGE- INSIDE

HEAD AT FLOATING FLANGE- PIPE SIDE

**ECFFL DIMENSIONS AND PRESSURE RATINGS (British & Metric Units) 2" (50mm) COMPRESSION, 1/2" (13mm) EXTENSION**

Type & Size	Pipe Size (in) (mm)	Overall Length (in) (mm)		ME	FE	Outer Housing O.D. (in) (mm)		Nominal Bellows Clearance			Spring Rate		Thrust <sup>1</sup> @ 200 psi (13.8 bar)		Rated Pressure @ 70°F (21°C)		Ship Wt.	
		(in)	(mm)	(in) (mm)	(in) (mm)	(in) (mm)	(in) (mm)	Inside (in) (mm)	Outside (in) (mm)	(lbs/in) (kg/cm)	(lbs) (kg)	(psi) (kg/cm²)	(psi) (kg/cm²)	(lbs) (kg)	(lbs) (kg)			
ECFFL-3/4	3/4 20	12 1/2	318	3 1/2 89	13/4 44	27/8 73	0.10 3	0.43 11	89 16	350 159	200 14	11 5						
ECFFL-1	1 25	12 1/2	318	3 1/2 89	13/4 44	3 1/2 89	0.13 3	0.55 14	95 17	500 227	200 14	14 6						
ECFFL-1 1/4	1 1/4 32	13	330	3 3/4 95	2 51	4 102	0.15 4	0.47 12	103 18	800 363	200 14	15 7						
ECFFL-1 1/2	1 1/2 40	13	330	3 3/4 95	2 51	4 1/2 114	0.17 4	0.46 12	106 19	1100 499	200 14	19 9						
ECFFL-2	2 50	13 1/2	343	4 1/8 105	2 1/8 54	5 1/4 133	0.17 4	0.52 13	110 20	1600 726	200 14	24 11						
ECFFL-2 1/2	2 1/2 65	14 1/4	362	4 1/4 108	2 1/4 55	6 1/4 159	0.24 6	0.53 14	126 23	2400 1089	200 14	35 16						
ECFFL-3	3 80	14 3/4	375	4 1/2 115	2 1/2 65	6 5/8 168	0.32 8	0.37 9	140 25	3500 1588	200 14	47 21						
ECFFL-4	4 100	14 3/4	375	4 1/2 115	2 1/2 65	8 5/8 219	0.33 8	0.81 21	150 27	5200 2359	200 14	70 32						

<sup>1</sup>Lower Thrust Forces in proportion at lower pressures, i.e. 100 psi Force = 100/225 x published Thrust. Forces on Pipe Anchors must include Thrust Force and Spring Force. Spring Force is determined by multiplying the joint Spring Rate by its Thermal Movement (in/mm).

**GUIDE SPACING - Referencing Pipe Diameter "D"**

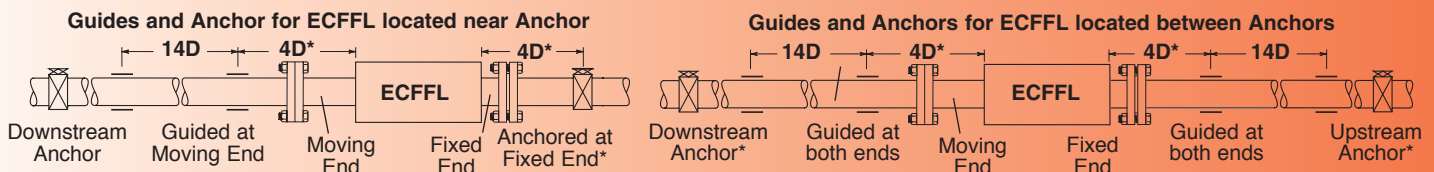

\*Plus an additional 3" (76mm) for Sizes 3/4 to 2 1/2

Bellows are externally pressurized.  
3.5 Minimum Safety Factor for both  
Bellows and Housing.

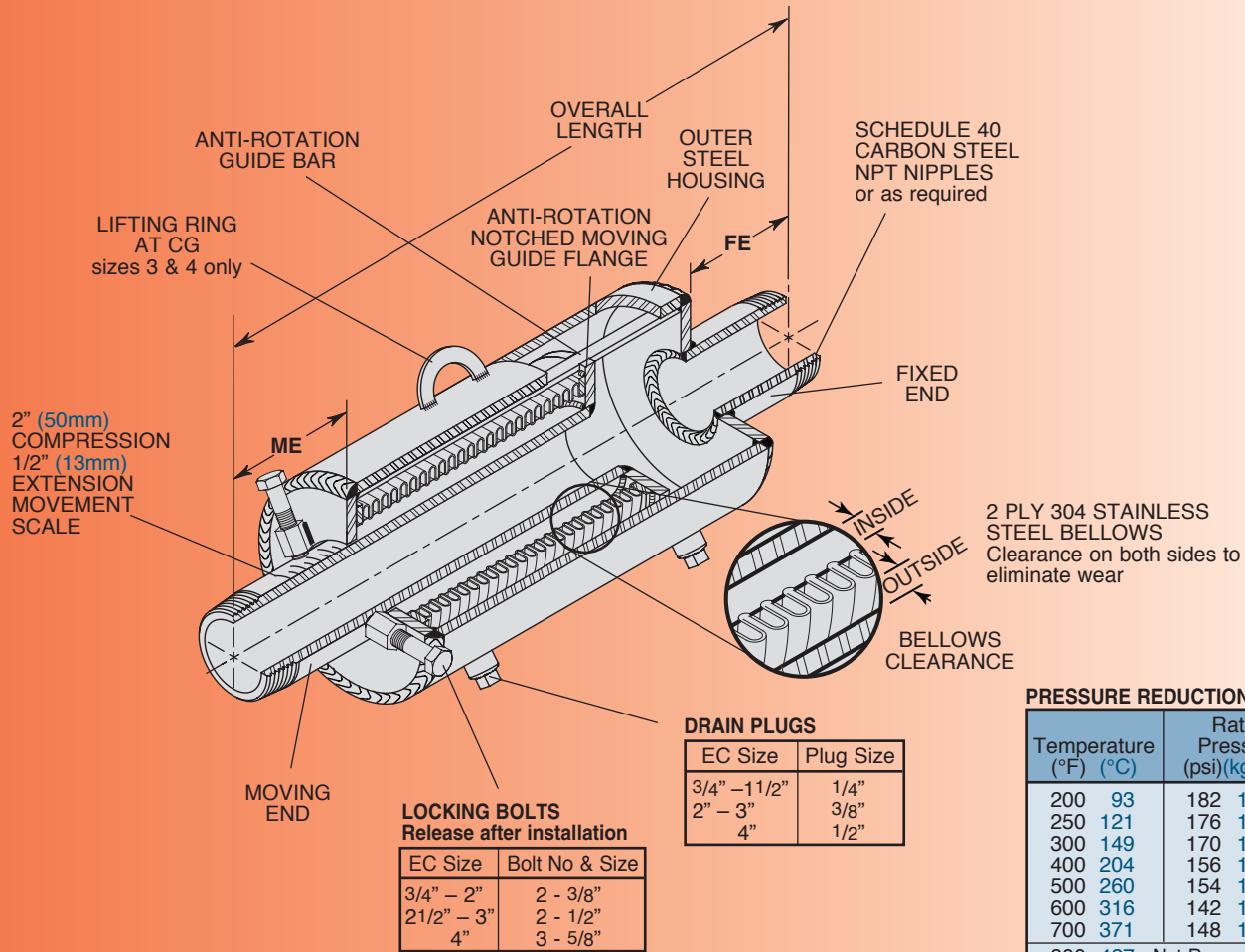

Vacuum Rating is 30 in (762mm) Hg

**ECMN DIMENSIONS AND PRESSURE RATINGS (British & Metric Units) 2" (50mm) COMPRESSION, 1/2" (13mm) EXTENSION**

Type & Size	Pipe Size (in) (mm)	Overall Length (in) (mm)	ME		FE		Outer Housing O.D.		Nominal Bellows Clearance		Spring Rate (lbs/in) (kg/cm)	Thrust <sup>1</sup> @ 200 psi / 13.8 bar		Rated Pressure @ 70°F / 21°C (psi) (kg/cm²)	Ship Wt. (lbs) (kg)
			Moving End Neutral Length (in) (mm)	Fixed End Length (in) (mm)	Inside (in) (mm)	Outside (in) (mm)	(lbs) (kg)	(lbs) (kg)							
ECMN-3/4	3/4 20	12 1/2 318	33/4 95	15/8 40	27/8 73	0.10 3	0.43 11	89 16	350 159	200 14	7 3				
ECMN-1	1 25	12 1/2 318	33/4 95	15/8 40	31/2 89	0.13 3	0.55 14	95 17	500 227	200 14	10 4				
ECMN-1 1/4	1 1/4 32	13 330	4 100	17/8 46	4 102	0.15 4	0.47 12	103 18	800 363	200 14	11 5				
ECMN-1 1/2	1 1/2 40	13 330	4 100	17/8 46	4 1/2 114	0.17 4	0.46 12	106 19	1100 499	200 14	13 6				
ECMN-2	2 50	13 1/2 343	4 1/8 103	2 1/8 53	5 1/4 133	0.17 4	0.52 13	110 20	1600 726	200 14	16 7				
ECMN-2 1/2	2 1/2 65	14 1/4 362	4 3/8 110	2 1/4 55	6 1/4 159	0.24 6	0.53 14	126 23	2400 1089	200 14	23 10				
ECMN-3	3 80	14 3/4 375	4 1/2 115	2 1/2 65	6 5/8 168	0.32 8	0.37 9	140 25	3500 1588	200 14	32 15				
ECMN-4	4 100	14 3/4 375	4 1/2 115	2 1/2 65	8 5/8 219	0.33 8	0.81 21	150 27	5200 2359	200 14	50 23				

<sup>1</sup>Lower Thrust Forces in proportion at lower pressures, i.e. 100 psi Force = 100/225 x published Thrust. Forces on Pipe Anchors must include Thrust Force and Spring Force. Spring Force is determined by multiplying the joint Spring Rate by its Thermal Movement (in/mm).

**GUIDE SPACING – Referencing Pipe Diameter "D"**

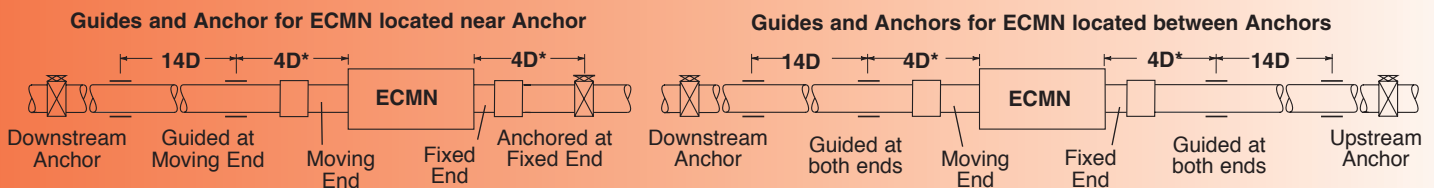

\*Plus an additional 3" (76mm) for Sizes 3/4 to 2 1/2

Bellows are externally pressurized.  
3.5 Minimum Safety Factor for both  
Bellows and Housing.

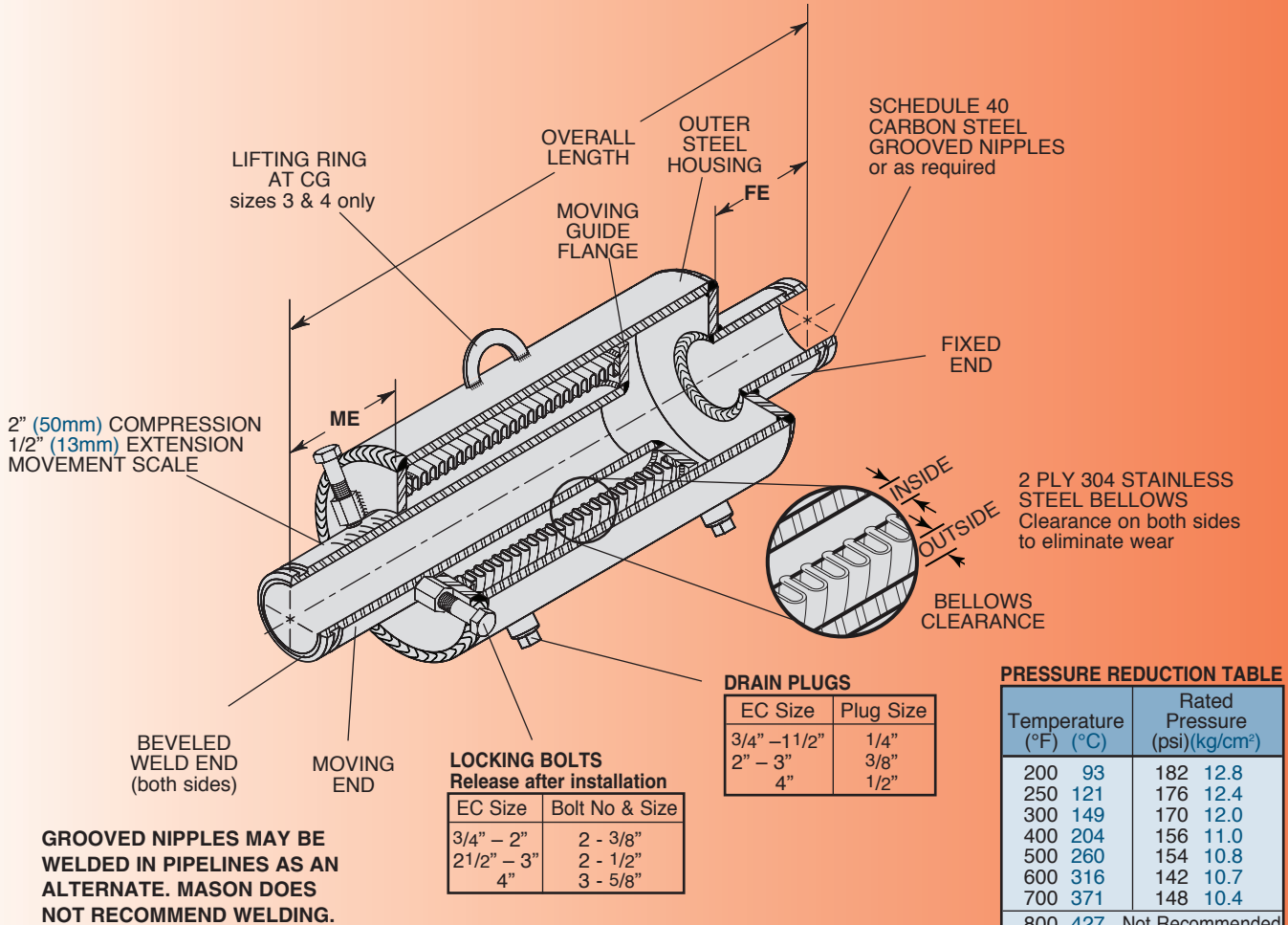

Vacuum Rating is 30 in (762mm) Hg

**ECWGN DIMENSIONS AND PRESSURE RATINGS (British & Metric Units) 2" (50mm) COMPRESSION, 1/2" (13mm) EXTENSION**

Type & Size	Pipe Size		Overall Length		ME Moving End Neutral Length		FE Fixed End Length		Outer Housing O.D.		Nominal Bellows Clearance		Spring Rate		Thrust <sup>†</sup> @ 200 psi / 13.8 bar		Rated Pressure @ 70°F / 21°C		Ship Wt.			
	(in)	(mm)	(in)	(mm)	(in)	(mm)	(in)	(mm)	(in)	(mm)	Inside (in)	Outside (in)	(lbs/in)	(kg/cm)	(lbs)	(kg)	(psi)	(kg/cm <sup>2</sup> )	(lbs)	(kg)		
ECWGN-3/4	3/4	20	12 1/2	318	3 3/4	95	1 5/8	40	2 7/8	73	0.10	3	0.43	11	89	16	350	159	200	14	7	3
ECWGN-1	1	25	12 1/2	318	3 3/4	95	1 5/8	40	3 1/2	89	0.13	3	0.55	14	95	17	500	227	200	14	9	4
ECWGN-1 1/4	1 1/4	32	13	330	4	100	1 7/8	46	4	102	0.15	4	0.47	12	103	18	800	363	200	14	10	5
ECWGN-1 1/2	1 1/2	40	13	330	4	100	1 7/8	46	4 1/2	114	0.17	4	0.46	12	106	19	1100	499	200	14	13	6
ECWGN-2	2	50	13 1/2	343	4 1/8	103	2 1/4	55	5 1/4	133	0.17	4	0.52	13	110	20	1600	726	200	14	17	8
ECWGN-2 1/2	2 1/2	65	14 1/4	362	4 3/8	110	2 1/4	55	6 1/4	159	0.24	6	0.53	14	126	23	2400	1089	200	14	24	11
ECWGN-3	3	80	14 3/4	375	4 1/2	115	2 1/2	65	6 5/8	168	0.32	8	0.37	9	140	25	3500	1588	200	14	33	15
ECWGN-4	4	100	14 3/4	375	4 1/2	115	2 1/2	65	8 5/8	219	0.33	8	0.81	21	150	27	5200	2359	200	14	50	23

<sup>†</sup>Lower Thrust Forces in proportion at lower pressures, i.e. 100 psi Force = 100/225 x published Thrust. Forces on Pipe Anchors must include Thrust Force and Spring Force. Spring Force is determined by multiplying the joint Spring Rate by its Thermal Movement (in/mm).

**GUIDE SPACING – Referencing Pipe Diameter "D"**

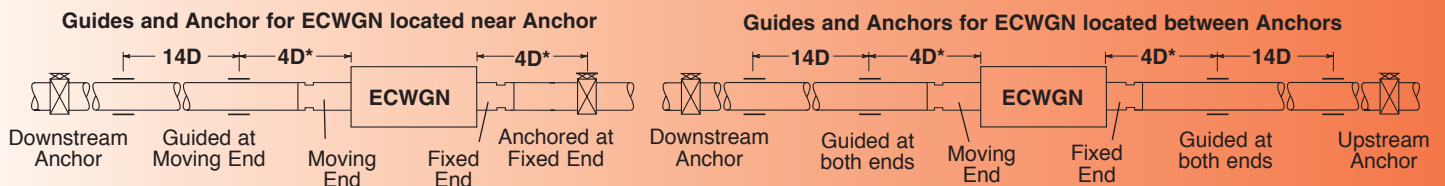

\*Plus an additional 3" (76mm) for Sizes 3/4 to 2 1/2



Bellows are externally pressurized.  
3.5 Minimum Safety Factor for both  
Bellows and Housing.

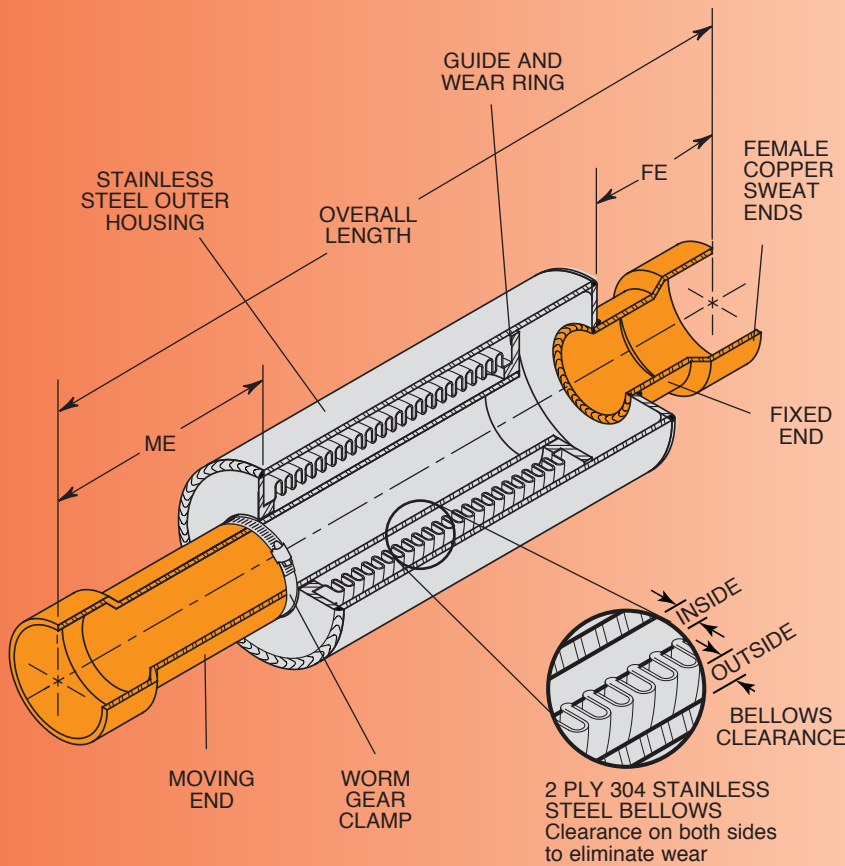

### INSTALLATION:

1. Thoroughly clean male and female ends using steel wool and steel brushes.
2. Apply flux.
3. Heat joint for proper flow of silver solder. Silver solder flows around 430°F. Composition is silver and tin only. There should be no lead content.
4. Do not use brazing rod or other high temperature techniques. Overheating will cause leaks.
5. Remove Worm Gear Clamp.

### PRESSURE REDUCTION TABLE

Temperature		Rated Pressure	
(°F)	(°C)	(psi)	(kg/cm <sup>2</sup> )
150	66	160	11
300	149	145	10
400	204	135	9

Vacuum Rating is 30 in (762mm) Hg

### ECCPS DIMENSIONS AND PRESSURE RATINGS (British & Metric Units) 2" (50mm) COMPRESSION, 1/2" (13mm) EXTENSION

Type & Size	Tubing Size <sup>††</sup> (in) (mm)	Overall Length (in) (mm)	ME		FE		Outer Housing O.D.		Nominal Bellows Clearance		Spring Rate (lbs/in) (kg/cm)	Thrust <sup>††</sup> @ 200 psi / 13.8 bar		Rated Pressure @ 70°F / 21°C (psi) (kg/cm <sup>2</sup> )	Ship Wt. (lbs) (kg)			
			Moving End Neutral Length (in) (mm)	Fixed End Length (in) (mm)	(in) (mm)	(in) (mm)	Inside (in) (mm)	Outside (in) (mm)	(lbs) (kg)	(lbs) (kg)								
ECCPS-3/4	3/4 20	111/2 292	31/8 79	15/8 40	2	51	0.17	4	0.11	3	23	4	320	145	200	14	2	1
ECCPS-1	1 25	111/2 292	31/8 79	15/8 40	2	51	0.22	6	0.13	3	44	8	520	236	200	14	2	1
ECCPS-11/4	11/4 32	12 305	31/2 89	13/4 44	23/4	70	0.20	5	0.22	6	50	9	630	286	200	14	3	2
ECCPS-11/2	11/2 40	12 305	31/2 89	13/4 44	23/4	70	0.17	4	0.20	5	98	18	750	340	200	14	4	2
ECCPS-2	2 50	121/4 311	33/4 95	13/4 44	31/2	89	0.16	4	0.13	3	168	30	1160	526	200	14	5	2
ECCPS-21/2	21/2 65	131/4 337	41/4 108	21/8 54	4	102	0.20	5	0.22	6	195	35	1810	821	200	14	6	3
ECCPS-3	3 80	131/4 337	41/4 108	21/8 54	41/4	114	0.21	5	0.28	7	316	57	2440	1107	200	14	7	3
ECCPS-4	4 100	141/2 368	43/8 111	21/2 65	6	150	0.14	4	0.30	8	350	63	3700	1678	200	14	25	11

<sup>††</sup>Female end fits over copper tubing, e.g. 11/2" (40mm) fits over 11/2" (40mm) tubing.

<sup>†</sup>Lower Thrust Forces in proportion at lower pressures, i.e. 100 psi Force = 100/225 x published Thrust. Forces on Pipe Anchors must include Thrust Force and Spring Force. Spring Force is determined by multiplying the joint Spring Rate by its Thermal Movement (in/mm).

### GUIDE SPACING – Referencing Pipe Diameter "D"

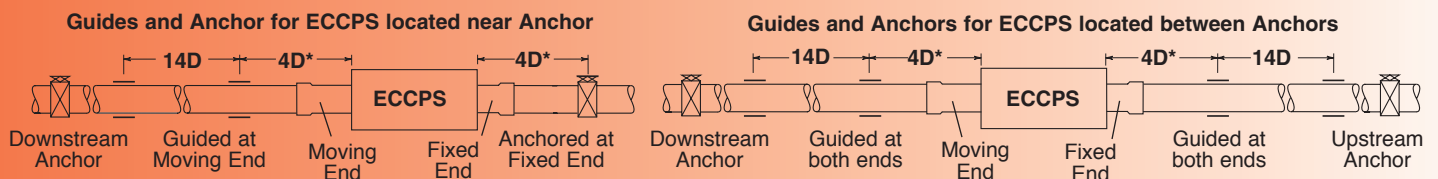

\*Plus an additional 3" (76mm) for Sizes 3/4 to 21/2

# HEJFFL

**HOUSED EXPANSION JOINT with FIXED and FLOATING FLANGES**

## HEJFFL8 8" (200mm) Movement

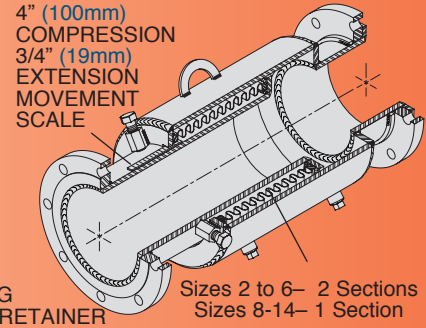
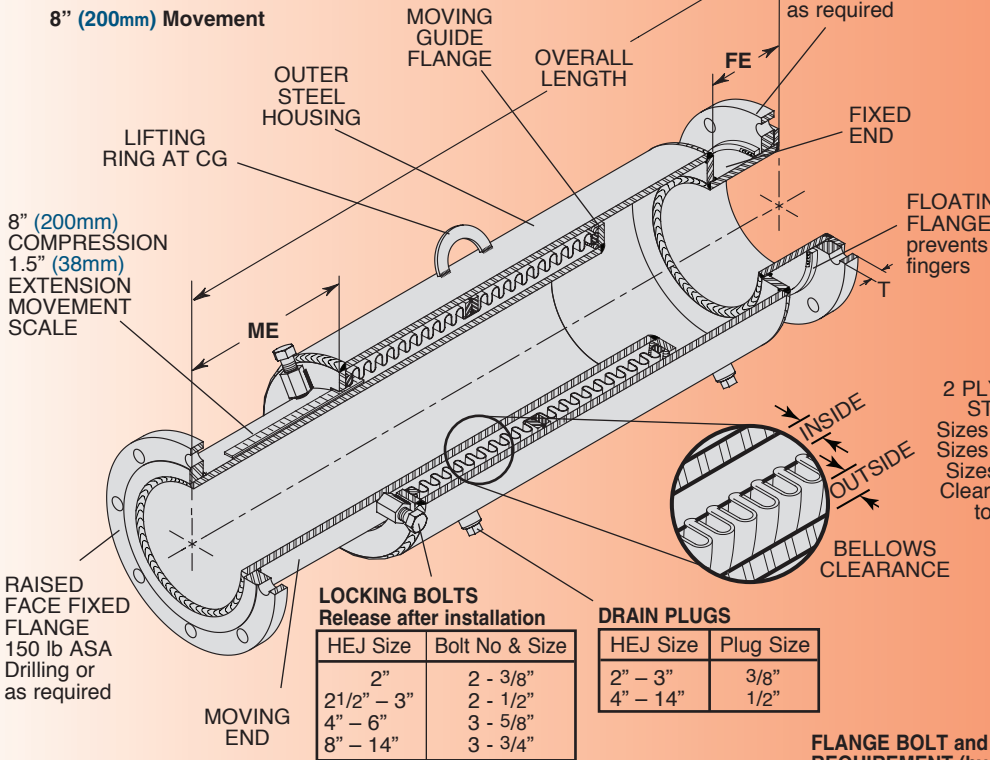

## HEJFFL4 4" (100mm) Movement

2 PLY 304 STAINLESS STEEL BELLOWS  
 Sizes 2 to 3- 4 Sections  
 Sizes 4 to 6- 3 Sections  
 Sizes 8-14- 2 Sections  
 Clearance on both sides to eliminate wear

Bellows are externally pressurized. 3.5 Minimum Safety Factor for both Bellows and Housing.

Vacuum Rating is 30 in (762mm) Hg

### LOCKING BOLTS Release after installation

HEJ Size	Bolt No & Size
2"	2 - 3/8"
2 1/2" - 3"	2 - 1/2"
4" - 6"	3 - 5/8"
8" - 14"	3 - 3/4"

### DRAIN PLUGS

HEJ Size	Plug Size
2" - 3"	3/8"
4" - 14"	1/2"

### FLANGE BOLT and NUT REQUIREMENT (by Others)

HEJFFL Size	Quantity	Size & Length
2 & 2 1/2	8	5/8 x 3
3	8	5/8 x 3 1/4
4	16	5/8 x 3 1/4
5 & 6	16	3/4 x 3 1/2
8	16	3/4 x 4
10	24	3/4 x 4
12	24	7/8 x 4 1/4
14	24	1 x 4 1/2

### PRESSURE REDUCTION TABLE

Temperature (°F)	Temperature (°C)	Rated Pressure (psi)	Rated Pressure (kg/cm²)
200	93	205	14.4
250	121	198	13.9
300	149	191	13.4
400	204	176	12.4
500	260	173	12.2
600	316	171	12.0
700	371	167	11.7
800	427	Not Recommended	

### CARBON STEEL PLATE FLANGE

Pipe Size (in)	Pipe Size (mm)	Flange Thickness T (in)	Flange Thickness T (mm)
2 thru 4	20 thru 100	5/8	16
5 thru 6	125 thru 150	3/4	19
8 thru 14	200 thru 350	1	25

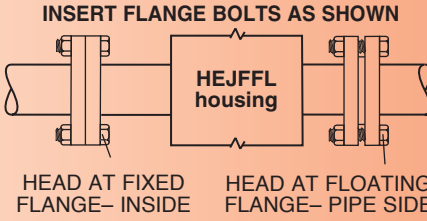

### HEJFFL4 DIMENSIONS AND PRESSURE RATINGS (British & Metric Units) 4" (100mm) COMPRESSION, 3/4" (19mm) EXTENSION

Type & Size	Pipe Size (in) (mm)	Overall Length (in) (mm)	ME Moving End Neutral Length (in) (mm)		FE Fixed End Length (in) (mm)		Outer Housing O.D. (in) (mm)	Nominal Bellows Clearance (in) (mm)		Spring Rate (lbs/in) (kg/cm)		Thrust <sup>†</sup> @ 225 psi 15.5 bar (lbs) (kg)		Rated Pressure @70°F @21°C (psi) (kg/cm²)	Ship Wt. (lbs) (kg)
			(in)	(mm)	(in)	(mm)		Inside	Outside	(in)	(mm)	(in)	(mm)		
HEJFFL4-2	2 50	261/2 673	83/8 213	31/8 79	59/16 141	141	0.39 10	0.39 10	165 30	2500 1134	225 16	50 23			
HEJFFL4-2 1/2	2 1/2 65	261/2 673	83/8 213	31/8 79	59/16 141	141	0.25 6	0.25 6	235 42	2700 1225	225 16	51 23			
HEJFFL4-3	3 80	261/2 673	83/8 213	31/8 79	65/8 168	168	0.32 8	0.33 8	240 43	3900 1769	225 16	65 29			
HEJFFL4-4	4 100	261/2 673	83/8 213	31/8 79	85/8 219	219	0.49 12	0.35 9	300 54	6900 3130	225 16	87 39			
HEJFFL4-5	5 125	281/2 723	83/8 213	4 1/8 105	95/8 244	244	0.39 10	0.41 10	400 72	9500 4309	225 16	90 41			
HEJFFL4-6	6 150	281/2 723	83/8 213	4 1/8 105	103/4 273	273	0.39 10	0.39 10	500 90	12600 5715	225 16	137 62			
HEJFFL4-8	8 200	281/2 723	83/8 213	4 1/8 105	123/4 384	384	0.39 10	0.39 10	600 107	19000 8618	225 16	180 82			
HEJFFL4-10	10 250	281/2 723	83/8 213	4 1/8 105	16 406	406	0.53 13	0.53 13	800 143	30000 13608	225 16	230 104			
HEJFFL4-12	12 300	281/2 723	83/8 213	4 1/8 105	18 457	457	0.42 11	0.41 10	1175 210	40000 18144	225 16	273 124			
HEJFFL4-14	14 350	30 762	83/8 213	4 1/8 105	20 500	500	0.43 11	0.42 11	1400 250	64000 29030	225 16	320 145			

### HEJFFL8 DIMENSIONS AND PRESSURE RATINGS (British & Metric Units) 8" (200mm) COMPRESSION, 1.5" (38mm) EXTENSION

Type & Size	Pipe Size (in) (mm)	Overall Length (in) (mm)	ME Moving End Neutral Length (in) (mm)		FE Fixed End Length (in) (mm)		Outer Housing O.D. (in) (mm)	Nominal Bellows Clearance (in) (mm)		Spring Rate (lbs/in) (kg/cm)		Thrust <sup>†</sup> @ 225 psi 15.5 bar (lbs) (kg)		Rated Pressure @70°F @21°C (psi) (kg/cm²)	Ship Wt. (lbs) (kg)
			(in)	(mm)	(in)	(mm)		Inside	Outside	(in)	(mm)	(in)	(mm)		
HEJFFL8-2	2 50	43 1092	107/8 276	31/8 79	59/16 141	141	0.39 10	0.39 10	83 15	2500 1134	225 16	50 23			
HEJFFL8-2 1/2	2 1/2 65	43 1092	107/8 276	31/8 79	59/16 141	141	0.25 6	0.25 6	118 21	2700 1225	225 16	51 23			
HEJFFL8-3	3 80	43 1092	107/8 276	31/8 79	65/8 168	168	0.32 8	0.33 8	120 22	3900 1769	225 16	65 29			
HEJFFL8-4	4 100	43 1092	107/8 276	31/8 79	85/8 219	219	0.49 12	0.35 9	150 27	6900 3130	225 16	87 39			
HEJFFL8-5	5 125	47 1194	127/8 327	4 1/8 105	95/8 244	244	0.39 10	0.41 10	200 36	9500 4309	225 16	90 41			
HEJFFL8-6	6 150	47 1194	127/8 327	4 1/8 105	103/4 273	273	0.39 10	0.39 10	250 45	12600 5715	225 16	137 62			
HEJFFL8-8	8 200	47 1194	127/8 327	4 1/8 105	123/4 384	384	0.39 10	0.39 10	300 54	19000 8618	225 16	180 82			
HEJFFL8-10	10 250	47 1194	127/8 327	4 1/8 105	16 406	406	0.53 13	0.53 13	400 72	30000 13608	225 16	230 104			
HEJFFL8-12	12 300	47 1194	127/8 327	4 1/8 105	18 457	457	0.42 11	0.41 10	588 105	40000 18144	225 16	273 124			
HEJFFL8-14	14 350	50 1270	127/8 327	4 1/8 105	20 500	500	0.43 11	0.42 11	700 125	64000 29030	225 16	320 145			

<sup>†</sup>Lower Thrust Forces in proportion at lower pressures, i.e. 100 psi Force = 100/225 x published Thrust. Forces on Pipe Anchors must include Thrust Force and Spring Force. Spring Force is determined by multiplying the joint Spring Rate by its Thermal Movement (in/mm).

Bellows are externally pressurized. 3.5 Minimum Safety Factor for both Bellows and Housing.

# HEJW

**HOUSED EXPANSION JOINT with WELD ENDS**

## HEJW8

8" (200mm) Movement

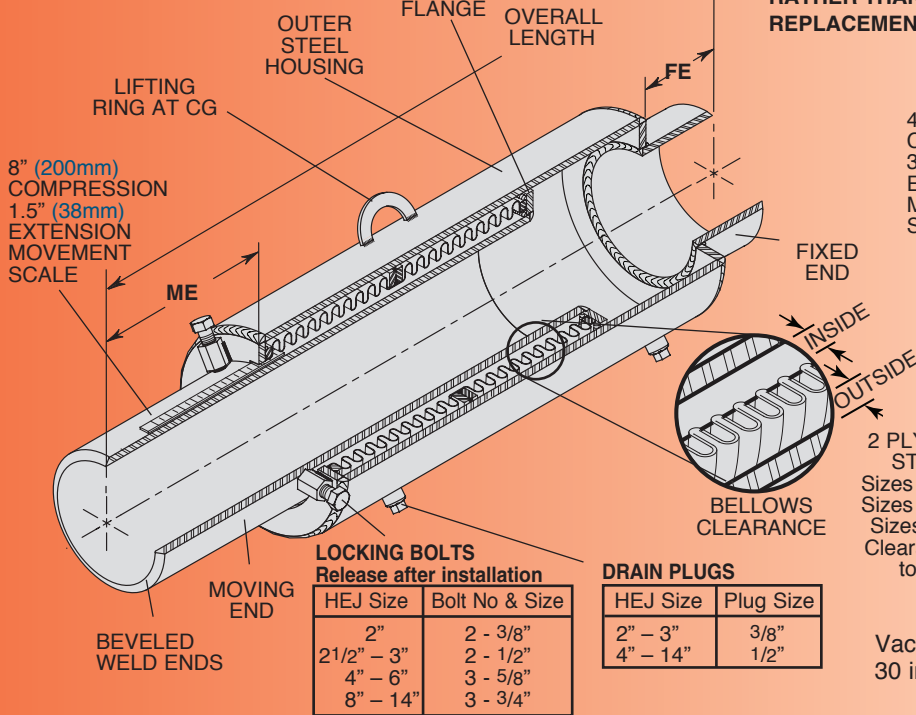

**MASON RECOMMENDS FLANGED ENDS RATHER THAN WELD ENDS FOR EASIER REPLACEMENT OR SERVICING.**

4" (100mm) COMPRESSION  
3/4" (19mm) EXTENSION  
MOVEMENT SCALE

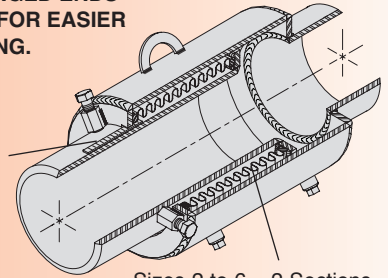

Sizes 2 to 6- 2 Sections  
Sizes 8-14- 1 Section

## HEJW4

4" (100mm) Movement

2 PLY 304 STAINLESS STEEL BELLOWS  
Sizes 2 to 3- 4 Sections  
Sizes 4 to 6- 3 Sections  
Sizes 8-14- 2 Sections  
Clearance on both sides to eliminate wear

### PRESSURE REDUCTION TABLE

Temperature (°F)	Temperature (°C)	Rated Pressure (psi)	Rated Pressure (kg/cm²)
200	93	205	14.4
250	121	198	13.9
300	149	191	13.4
400	204	176	12.4
500	260	173	12.2
600	316	171	12.0
700	371	167	11.7
800	427	Not Recommended	

Vacuum Rating is 30 in (762mm) Hg

**LOCKING BOLTS**  
Release after installation

HEJ Size	Bolt No & Size
2"	2 - 3/8"
2 1/2" - 3"	2 - 1/2"
4" - 6"	3 - 5/8"
8" - 14"	3 - 3/4"

**DRAIN PLUGS**

HEJ Size	Plug Size
2" - 3"	3/8"
4" - 14"	1/2"

### HEJW4 DIMENSIONS AND PRESSURE RATINGS (British & Metric Units) 4" (100mm) COMPRESSION, 3/4" (19mm) EXTENSION

Type & Size	Pipe Size		Overall Length		ME Moving End Neutral Length		FE Fixed End Length		Outer Housing O.D.		Nominal Bellows Clearance		Spring Rate		Thrust <sup>1</sup> @ 225 psi / 15.5 bar		Rated Pressure @ 70°F / 21°C	Ship Wt. (lbs)/(kg)				
	(in)	(mm)	(in)	(mm)	(in)	(mm)	(in)	(mm)	(in)	(mm)	(in)	(mm)	(in)	(mm)	(in)	(kg)						
HEJW4-2	2	50	22	559	5 1/2	140	1 1/2	38	59/16	141	0.39	10	0.39	10	165	30	2500	1134	225	16	50	23
HEJW4-2 1/2	2 1/2	65	22	559	5 1/2	140	1 1/2	38	59/16	141	0.25	6	0.25	6	235	42	2700	1225	225	16	51	23
HEJW4-3	3	80	22	559	5 1/2	140	1 1/2	38	65/8	168	0.32	8	0.33	8	240	43	3900	1769	225	16	65	29
HEJW4-4	4	100	24 1/2	622	6	152	1 1/2	38	85/8	219	0.49	12	0.35	9	300	54	6900	3130	225	16	87	39
HEJW4-5	5	125	24 1/2	622	6	152	2 1/2	64	95/8	244	0.39	10	0.41	10	400	72	9500	4309	225	16	90	41
HEJW4-6	6	150	24 1/2	622	6	152	2 1/2	64	103/4	273	0.39	10	0.39	10	500	90	12600	5715	225	16	137	62
HEJW4-8	8	200	24 1/2	622	6	152	2 1/2	64	123/4	384	0.39	10	0.39	10	600	107	19000	8618	225	16	180	82
HEJW4-10	10	250	24 1/2	622	6	152	2 1/2	64	16	406	0.53	13	0.53	13	800	143	30000	13608	225	16	230	104
HEJW4-12	12	300	24 1/2	622	6	152	2 1/2	64	18	457	0.42	11	0.41	10	1175	210	40000	18144	225	16	273	124
HEJW4-14	14	350	26	660	6	152	2 1/2	64	20	500	0.43	11	0.42	11	1400	250	64000	29030	225	16	320	145

### HEJW8 DIMENSIONS AND PRESSURE RATINGS (British & Metric Units) 8" (200mm) COMPRESSION, 1.5" (38mm) EXTENSION

Type & Size	Pipe Size		Overall Length		ME Moving End Neutral Length		FE Fixed End Length		Outer Housing O.D.		Nominal Bellows Clearance		Spring Rate		Thrust <sup>1</sup> @ 225 psi / 15.5 bar		Rated Pressure @ 70°F / 21°C	Ship Wt. (lbs)/(kg)				
	(in)	(mm)	(in)	(mm)	(in)	(mm)	(in)	(mm)	(in)	(mm)	(in)	(mm)	(in)	(mm)	(in)	(kg)						
HEJW8-2	2	50	40	1016	9 1/2	241	1 1/2	38	59/16	141	0.39	10	0.39	10	83	15	2500	1134	225	16	50	23
HEJW8-2 1/2	2 1/2	65	40	1016	9 1/2	241	1 1/2	38	59/16	141	0.25	6	0.25	6	118	21	2700	1225	225	16	51	23
HEJW8-3	3	80	40	1016	9 1/2	241	1 1/2	38	65/8	168	0.32	8	0.33	8	120	22	3900	1769	225	16	65	29
HEJW8-4	4	100	40	1016	9 1/2	241	1 1/2	38	85/8	219	0.49	12	0.35	9	150	27	6900	3130	225	16	87	39
HEJW8-5	5	125	42 1/2	1080	10	254	2 1/2	64	95/8	244	0.39	10	0.41	10	200	36	9500	4309	225	16	90	41
HEJW8-6	6	150	42 1/2	1080	10	254	2 1/2	64	103/4	273	0.39	10	0.39	10	250	45	12600	5715	225	16	137	62
HEJW8-8	8	200	42 1/2	1080	10	254	2 1/2	64	123/4	384	0.39	10	0.39	10	300	54	19000	8618	225	16	180	82
HEJW8-10	10	250	42 1/2	1080	10	254	2 1/2	64	16	406	0.53	13	0.53	13	400	72	30000	13608	225	16	230	104
HEJW8-12	12	300	42 1/2	1080	10	254	2 1/2	64	18	457	0.42	11	0.41	10	588	105	40000	18144	225	16	273	124
HEJW8-14	14	350	45 1/2	1156	10	254	2 1/2	64	20	500	0.43	11	0.42	11	700	125	64000	29030	225	16	320	145

<sup>1</sup>Lower Thrust Forces in proportion at lower pressures, i.e. 100 psi Force = 100/225 x published Thrust. Forces on Pipe Anchors must include Thrust Force and Spring Force. Spring Force is determined by multiplying the joint Spring Rate by its Thermal Movement (in/mm).

### GUIDE SPACING - Referencing Pipe Diameter "D"

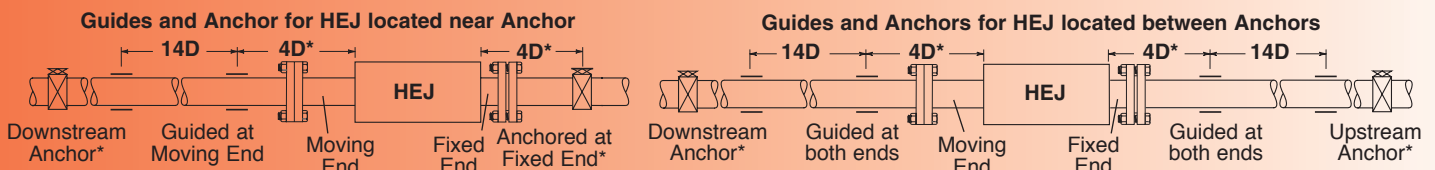

\*Plus an additional 5" (125mm) for Sizes 2 & 2 1/2

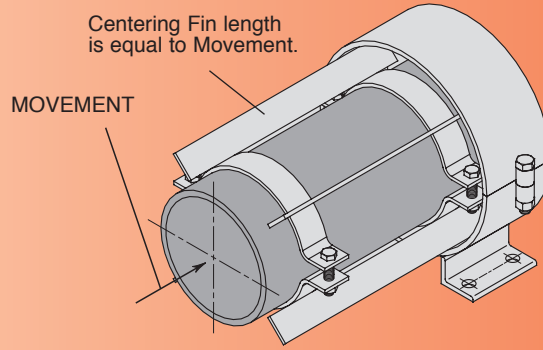

Typical GG through PP Two Clamp Configuration

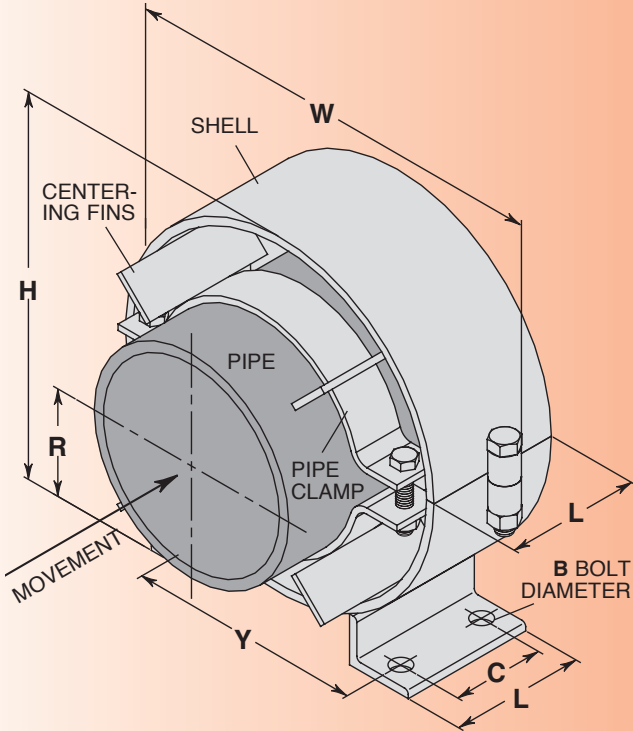

Typical AA through FF One Clamp Configuration

### SPG SHELL SELECTION TABLE for 4" (100mm), 6" (150mm) & 8" (200mm) MOVEMENT

Pipe Size (in)(mm)	SHELL CODE LETTERS							Max. Standard Mvmt. ±* (in)(mm)
	Insulation Thickness							
	1" 25mm	1 1/2" 32mm	2" 50mm	2 1/2" 65mm	3" 80mm	3 1/2" 90mm	4" 100mm	
1/2 15	AA	AA	BB	DD	DD	DD	EE	4 100
3/4 20	AA	BB	CC	DD	DD	EE	EE	4 100
1 25	AA	BB	CC	DD	DD	EE	EE	4 100
1 1/4 32	AA	BB	CC	DD	DD	EE	EE	4 100
1 1/2 40	BB	BB	CC	DD	DD	EE	EE	4 100
2 50	BB	CC	DD	DD	EE	EE	FF	4 100
2 1/2 65	CC	CC	DD	DD	EE	EE	FF	4 100
3 80	CC	DD	DD	EE	FF	FF	FF	4 100
4 100	DD	DD	EE	EE	FF	FF	GG	6 150
5 125	EE	EE	EE	FF	FF	GG	HH	6 150
6 150	EE	EE	FF	FF	GG	HH	HH	6 150
8 200	FF	FF	GG	HH	HH	JJ	JJ	6 150
10 250	HH	HH	HH	JJ	JJ	KK	KK	6 150
12 300	JJ	JJ	JJ	KK	KK	LL	LL	8 150
14 350	KK	KK	KK	KK	LL	LL	MM	8 150
16 400	LL	LL	LL	LL	MM	MM	NN	8 150
18 450	MM	MM	MM	MM	NN	NN	NN	8 150
20 500	NN	NN	NN	NN	PP	PP	PP	8 150
24 600	PP	PP	PP	PP	—	—	—	8 150

\*Centering Fin length is equal to the Maximum Standard Movement. Non-standard movements are available.

### SPG DIMENSIONS (inches)

Type	Shell Code	H	R	W	Y	B	C	L
SPG	AA	57/8	31/2	61/8	41/8	5/8	13/4	3
SPG	BB	63/4	4	71/8	43/8	5/8	13/4	3
SPG	CC	75/8	43/8	81/8	51/8	5/8	13/4	3
SPG	DD	91/4	51/4	101/8	61/8	5/8	13/4	3
SPG	EE	115/8	61/4	121/8	7	5/8	23/4	4
SPG	FF	133/8	7	141/8	81/4	5/8	23/4	4
SPG	GG	151/8	77/8	161/8	97/8	3/4	4	6
SPG	HH	17	87/8	181/8	107/8	3/4	4	6
SPG	JJ	183/4	93/4	201/8	117/8	3/4	4	6
SPG	KK	21	107/8	221/8	113/4	3/4	6	8
SPG	LL	231/8	121/8	241/8	141/2	7/8	6	8
SPG	MM	25	13	261/8	151/2	7/8	6	8
SPG	NN	273/4	143/4	281/8	171/8	11/8	6	8
SPG	PP	311/2	161/2	321/8	191/4	11/8	6	8

### SPG DIMENSIONS (mm)

Type	Shell Code	H	R	W	Y	B	C	L
SPG	AA	149	90	156	104	16	44	76
SPG	BB	171	102	181	111	16	44	76
SPG	CC	194	111	206	130	16	44	76
SPG	DD	235	133	257	156	16	44	76
SPG	EE	295	159	308	178	16	70	102
SPG	FF	340	178	360	210	16	70	102
SPG	GG	384	200	410	251	19	102	152
SPG	HH	432	225	460	276	19	102	152
SPG	JJ	476	248	511	302	19	102	152
SPG	KK	533	276	562	298	19	152	203
SPG	LL	587	308	613	368	22	152	203
SPG	MM	635	330	664	394	22	152	203
SPG	NN	705	375	714	435	22	152	203
SPG	PP	800	419	816	489	22	152	203



# MASON – MERCER

350 Rabro Drive, Hauppauge, NY 11788 • FAX 631/348-0279

MASON– 631/348-0282 • Email info@Mason-Ind.com • Website www.Mason-Ind.com  
 MERCER– 631/582-1524 • Email info@Mercer-Rubber.com • Website www.Mercer-Rubber.com



7/10  
SP107

Printed  
in U.S.A.