

MASON-MERCER

ADJUSTABLE SLIDING GUIDE

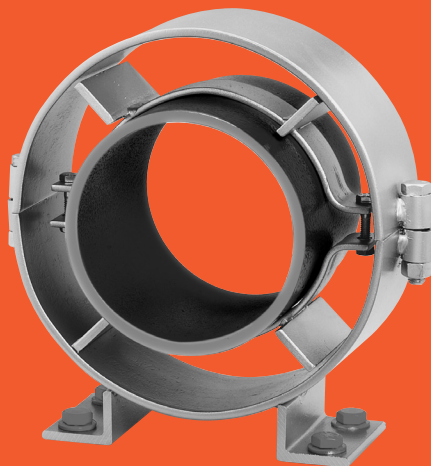

Typical Spider Guide

All of us have gotten accustomed to using Spider Pipe Guides because they have been around forever. In looking for a better way, we found the following areas for improvement:

1) There is no single Spider Guide for any pipe size. The ID is standard, but the length of the guide fins and the ID of the housing all vary with insulation thickness. There can be as many as five selections for the same diameter pipe.

This makes stocking difficult and the contractor cannot buy without knowing the insulation thickness.

2) While they are used in other positions, most Spider Guide have no allowable load ratings as they are single purpose Guides.

Our primary objective was to solve these two problems so we came up with the idea of a simple insulation height adjustment. Just loosen two bolts on each side of the base and move to the higher position when job requirements call for thicker insulation. Not only are they easier to order and dimension, but the price remains the same regardless of insulation thickness. This is not true with the spider design as cost is based on the shell OD. Cost estimates are no longer difficult with our single price per size.

The next problem was addressed by our design team of Professional Engineers. The rating in any guide position is at least the support value required for the maximum unsupported length of piping. According to code, maximum hanger spacing for a 2" pipe is every 10' whereas a 12" line goes out to as much as 23'. In most installations it is just easier to locate all supports at 10' spacing, but our designs allow for the longer criteria as shown in the table on page 3.

In addition to the published support values, you will find that most of the baseplates have a multitude of holes. This is very helpful as you do not always know how they are going to be installed. The large centered hole is for bolting to concrete, the close holes off the center line are for bolting through the flanges of beams. The wider spread is used when there is a steel surface wide enough to take advantage of that spacing.

Travel is another major concern. All of our guides have travel at least equal to standard Spider Guides

and many considerably more without going to special designs.

Our installation instructions tell the installer how to best position the guide to accommodate maximum or limited travel.

Excessive friction or galling is another major concern. Internal parts in Spider Guides are generally sheared and welded to the inner clamp at 90° intervals. No matter how carefully the installer tries, there are still sharp edges that cut into the outer housing. Rather than just sliding, you may have to overcome gall. They show no concern about rust deterioration as everything is just painted carbon steel.

In our new design, both the sliding foot and the interior of the outside guides are wrapped or lined in Stainless Steel as illustrated. There can be little or no corrosion, and the force needed to move the guide is minimal as compared to sharp edged carbon steel configurations.

Always install in Lower Position when Pipe is not insulated or when Insulation Thickness does not exceed the Lower Position Maximum Insulation Thickness shown in the table below. For Overall Height, add Insulation Thickness to H_L or H_U .

In copper or brass water or steam systems, Dielectric Spacers supplied by Mason must be used to prevent leakage from galvanic action. These simple lead strips are installed between our steel clamps and the copper or brass piping, top and bottom.

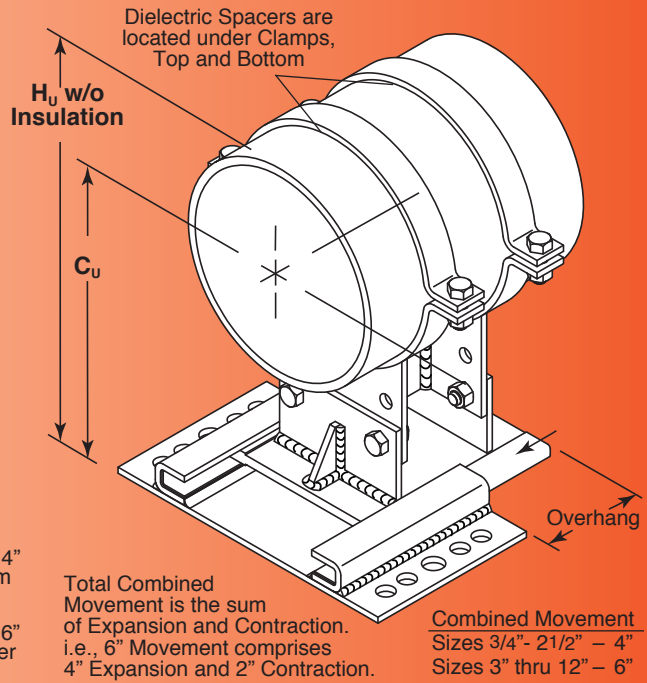
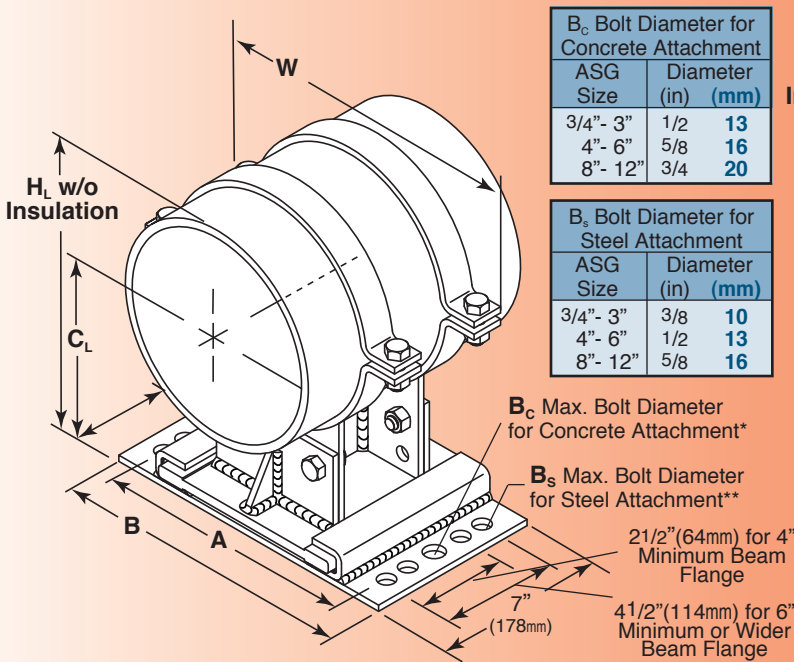

ASG LOWER POSITION C_L & H_L
Sizes 3/4" to 12" 2 1/2" Insulation Max.

Type & Pipe Size (in) (mm)	Q Pipe Height C_L (in) (mm)	Overall Height without Insulation H_L (in) (mm)	Maximum Insulation Thickness Lower Position (in) (mm)
ASG-3/4 20	33/4 95	4 1/2 114	2 51
ASG-1 25	4 1/8 105	5 127	2 51
ASG-1 1/4 32	4 3/8 111	5 3/8 137	2 51
ASG-1 1/2 40	4 1/2 114	5 5/8 143	2 51
ASG-2 50	4 3/4 121	6 1/8 156	2 51
ASG-2 1/2 65	5 127	6 5/8 168	2 51
ASG-3 80	5 3/8 137	7 1/4 184	2 1/2 65
ASG-4 100	6 5/8 168	9 229	2 1/2 65
ASG-5 125	7 1/8 181	10 1/16 255	2 1/2 65
ASG-6 150	7 5/8 194	11 1/8 283	2 1/2 65
ASG-8 200	9 229	13 1/2 343	2 1/2 65
ASG-10 250	10 1/2 267	16 406	2 1/2 65
ASG-12 300	11 1/2 292	18 3/8 467	2 1/2 65

*Use two bolts for concrete attachment.
**Use four bolts for steel attachment.
Use inner holes for narrow steel flange widths or outer holes for wider flanges.

ASG UPPER POSITION C_U & H_U
Sizes 1" to 12" for 3" to 4" Insulation
Note: 3/4" size cannot be raised

A (in) (mm)	B (in) (mm)	W (in) (mm)
5 1/2 140	6 3/4 172	3 1/4 83
6 152	7 1/4 184	3 5/8 92
6 152	7 1/4 184	4 102
6 152	7 1/4 184	4 1/4 108
6 152	7 1/4 184	4 3/4 121
6 152	7 1/4 184	5 1/4 133
6 1/2 164	7 3/4 196	6 152
7 1/4 184	8 1/2 216	7 1/4 184
8 204	9 1/4 235	8 1/2 216
8 3/4 222	10 254	9 1/2 240
10 1/2 267	12 1/4 311	11 3/4 298
11 1/2 292	13 1/4 337	14 5/8 372
13 330	14 3/4 375	16 3/4 426

Type & Pipe Size (in) (mm)	Q Pipe Height C_U (in) (mm)	Overall Height without Insulation H_U (in) (mm)	Max. Insulation Thickness Upper Position (in) (mm)
ASG-3/4 20	33/4 95	4 1/2 114	2 51
ASG-1 25	5 1/8 130	6 152	3 76
ASG-1 1/4 32	5 3/8 137	6 3/8 162	3 76
ASG-1 1/2 40	5 1/2 140	6 5/8 168	3 76
ASG-2 50	5 3/4 146	7 1/2 181	3 76
ASG-2 1/2 65	6 152	7 5/8 194	3 76
ASG-3 80	6 3/8 162	8 1/4 210	4 102
ASG-4 100	8 1/8 206	10 1/2 267	4 102
ASG-5 125	8 5/8 219	11 1/16 294	4 102
ASG-6 150	9 1/8 232	12 5/8 321	4 102
ASG-8 200	10 1/2 267	15 381	4 102
ASG-10 250	12 305	17 1/2 445	4 102
ASG-12 300	13 330	19 7/8 505	4 102

LARGER SIZES ARE DESIGNED AND BUILT TO ORDER

ASG Guides are most commonly installed with their base plates bolted down. However, they can be used as guides for horizontal runs when bolted to walls or columns or for overhead runs when bolted to ceilings or overhead steel. Check Anchorage Capacity when bolting to ceilings†.

If support is provided by other means such as rollers, guide spacing would be based on guidance spacing requirements rather than loadings.

Guides as Supports

Most guide manufacturers publish no guide support strength information because their guides are designed for the single purpose of maintaining alignment.

When the guides are spaced properly for that single purpose, forces are small and housing strength is seldom an issue.

In many applications there can be a major savings in using the guide as a support rather than just a guide in all horizontal runs. For example, if we were supporting 23 feet of 12" piping weighing 4000 lbs. on ASG Guides only and the Guide ratings show acceptance of the load in that position, there is no need for another support. Dry steel to steel friction is about 70% so 2800 lbs. (0.70 x 4000 lbs.) would have to be added to the appropriate anchor loading. Friction is usually a very small proportion of anchor loading.

ASG LOAD RATINGS

ASG Pipe Size (in) (mm)	Rated Base Mounted Pipe Load* (lbs) (kgs)		†Rated Hanging Pipe Load* (lbs) (kgs)		Rated Transverse Pipe Load* (lbs) (kgs)		Normal Guide Spacing if used as only Support (ft) (m)		Normal Guide Load if used as only Support (lbs) (kgs)		Maximum Guide Spacing if used as only Support** (ft) (m)		Maximum Guide Load if used as only Support (lbs) (kgs)		Standard Weight Carbon Steel Pipe with Water and Insulation (lbs/ft) (kg/m)		
3/4	20	1200	544	1200	544	750	340	5	1.5	10	4.5	7	2.1	14	6.4	2.0	3.0
1	25	1200	544	1200	544	750	340	5	1.5	12	5.4	7	2.1	17	7.7	2.4	3.6
1 1/4	32	1200	544	1200	544	750	340	5	1.5	16	7.3	7	2.1	23	10.4	3.3	4.9
1 1/2	40	1200	544	1200	544	750	340	8	2.4	32	14.5	9	2.7	36	16.3	4.0	6.0
2	50	1200	544	1200	544	750	340	10	3.0	56	25.4	10	3.0	56	25.4	5.6	8.3
2 1/2	65	1200	544	1200	544	750	340	10	3.0	86	39.0	11	3.5	95	43.0	8.4	12.5
3	80	1850	839	1700	771	1000	454	10	3.0	114	51.7	12	3.7	137	62.1	11.4	17.0
4	100	1900	862	1800	816	1050	476	10	3.0	169	76.7	14	4.3	237	108.0	16.9	25.2
5	125	1925	873	1830	830	1100	499	10	3.0	251	113.9	16	4.9	402	183.0	25.1	37.4
6	150	1950	885	1950	885	1300	590	10	3.0	330	149.7	17	5.2	561	255.0	33.0	49.1
8	200	3050	1383	2775	1259	1850	839	10	3.0	530	240.4	19	5.8	1007	457.0	53.0	78.9
10	250	5550	2517	4350	1973	2750	1247	10	3.0	774	351.0	22	6.7	1703	772.0	77.4	115.2
12	300	5600	2540	5600	2540	3950	1792	10	3.0	1060	480.8	23	7.0	2438	1105.0	106.0	157.8

* All Safety Factors meet or exceed 5.

** Manufacturers Standardization Society (MSS-SP-69) maximum spacing for standard weight carbon steel pipe with water and insulation.

ALL MODE ASG INSTALLATION POSITIONS

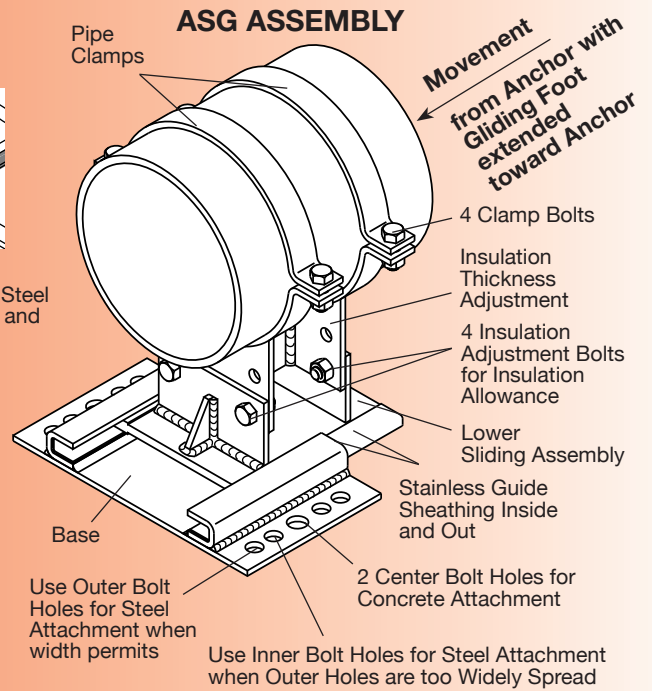
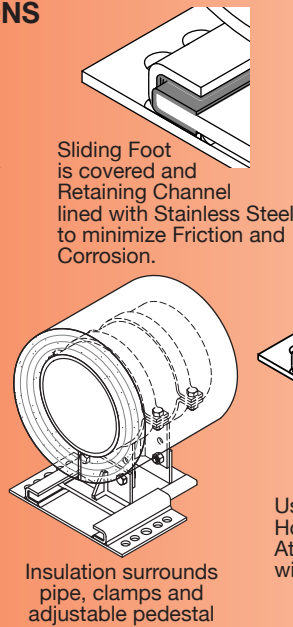
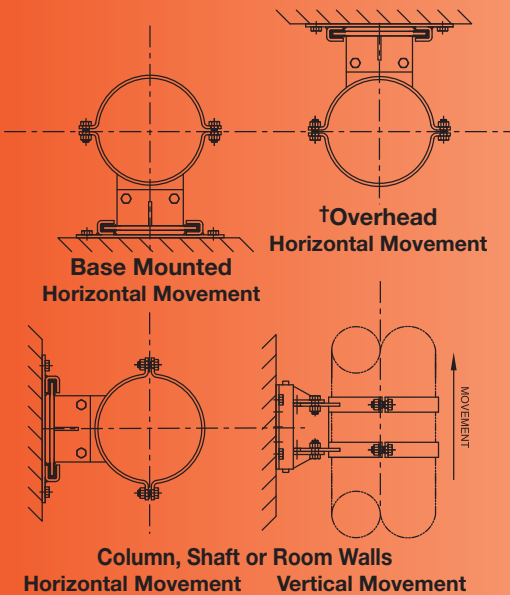

ASG WELDED POSITIONS and WELD LOCATIONS

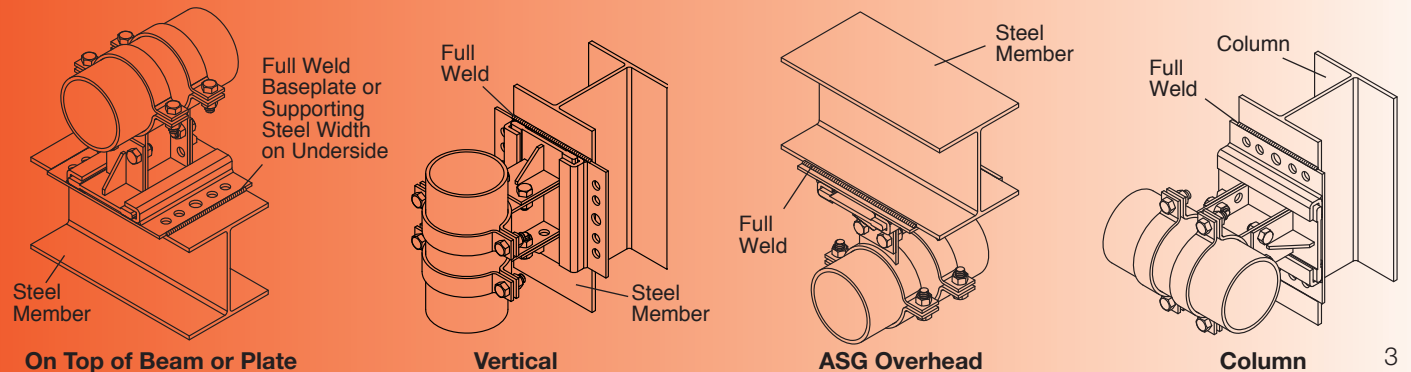

PIPE GUIDES AND GUIDING

Correct alignment of pipe as provided by guides is vital for the proper performance and life of an Expansion Joint. Pipe expansion joints will apply compressive loads to the pipe line, which may cause pipe to buckle when not properly guided. Buckling can be caused by the spring constant or resistance of the expansion joint, plus the pressure thrust from the expansion joint. Proper pipe guiding near an expansion joint starts with locating the first guide within 4 diameters of the expansion joint, and the second guide within 14 diameters of the first guide. For long runs of pipe, additional guides may be needed to prevent buckling as determined by the Intermediate Guide Spacing Chart shown below. Note that as the pressure increases, the intermediate guide spacing decreases because of the increased buckling force.

In addition to the locations of the anchors and guides to protect expansion joints and control movements as shown above, there are often long lengths of pipe between anchors or guides that would buckle like over-loaded columns.

Checking the Intermediate Guide Spacing Chart will show when additional Guides are needed.

To use the Chart, select the maximum pressure and move up to intersection with the red Pipe Size line. Follow horizontally all the way to the left and read maximum guide spacing.

For Example:

A 5" 200 psi steel line must be guided every 30 feet to prevent buckling when expansion joints are used.

At 110 psi the Guide Spacing would increase to 40 feet.

At 450 psi it would drop to 20 feet.

GUIDE SPACING – Referencing Pipe Diameter “D”

Guides and Anchors for Joint located near Anchor

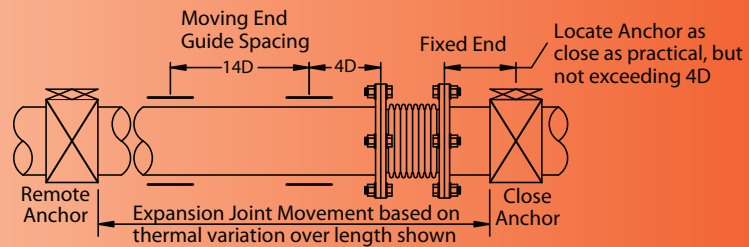

Guides and Anchors for Joint located between Remote Anchors

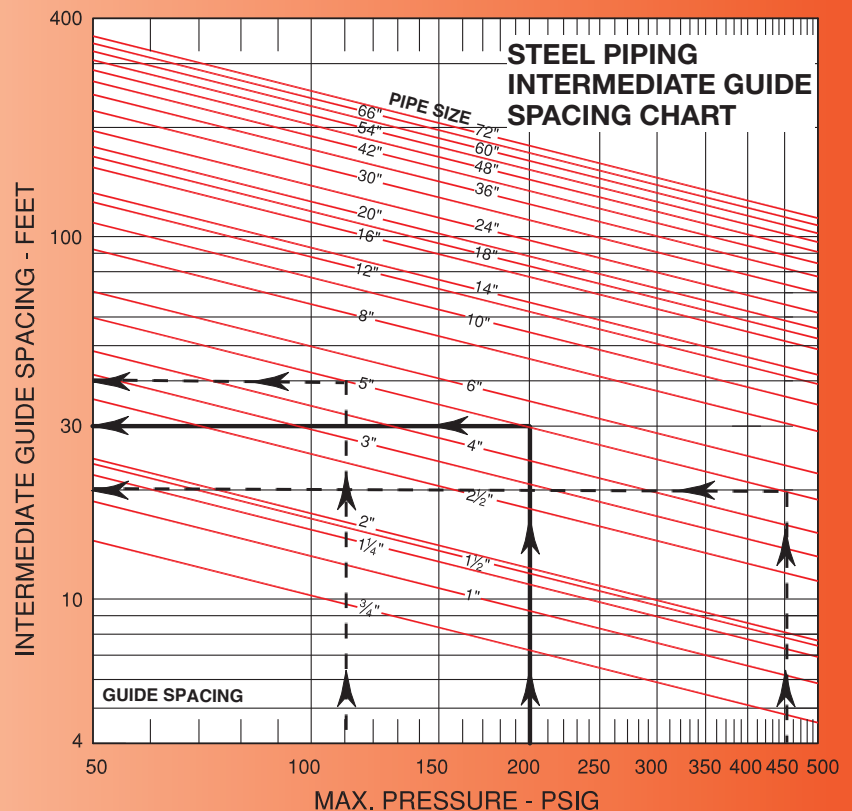
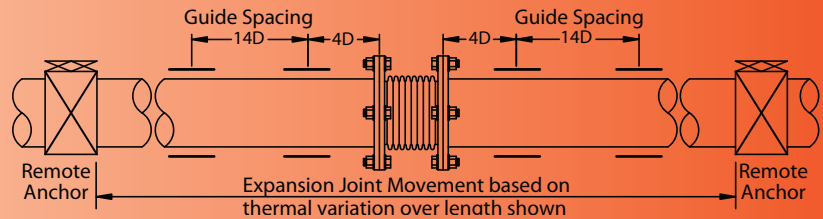

SPECIFICATION

Pipe guides shall be manufactured with stainless steel wrapping the carbon steel foot where it passes through horizontal U guides similarly lined to prevent corrosion. The baseplate shall have multiple holes for bolting to beam flanges or flat surfaces. Bases may be welded in position in lieu of bolting. Height must be

adjustable to accept different thicknesses of insulation. Guides shall be professionally load rated for bottom, overhead, side mounted or riser positioning to provide both load bearing and guiding capabilities. Submittals shall include load ratings in all modes. Guides shall be type ASG as manufactured by Mason Industries, Inc.



MASON – MERCER



350 Rabro Drive, Hauppauge, NY 11788 • FAX 631/348-0279

MASON– 631/348-0282 • Email info@Mason-Ind.com • Website www.Mason-Ind.com

MERCER– 631/582-1524 • Email info@Mercer-Rubber.com • Website www.Mercer-Rubber.com