

**MASON INDUSTRIES, Inc.**
*Manufacturers of Vibration Control Products*
*NY Reply to: PO Box 410, Smithtown, NY 11787*

350 Rabro Drive Hauppauge, NY 11788 631/348-0282 FAX 631/348-0279 Info@Mason-Ind.com	2101 W. Crescent Ave., Suite D Anaheim, CA 92801 714/535-2727 FAX 714/535-5738 Info@MasonAnaheim.com
--	--

**COMPLETE  
SEISMIC HVAC  
ENGINEERING  
SPECIFICATIONS**
**Norm Mason P.E.  
James Tauby P.E.**
**SVCS**
**PART 2**
**SVCS-110-5 BULLETIN**
**Part 1 - GENERAL**
**1.01 Description**
**A. Intent**

1. All mechanical equipment, piping and ductwork as noted on the equipment schedule or in the specification shall be mounted on vibration isolators to prevent the transmission of vibration and mechanically transmitted sound to the building structure. Vibration isolators shall be selected in accordance with the weight distribution so as to produce reasonably uniform deflections.
2. All isolators and isolation materials shall be of the same manufacturer and shall be certified by the manufacturer.
3. It is the intent of the seismic portion of this specification to keep all mechanical and electrical building system components in place during a seismic event.
4. All such systems must be installed in strict accordance with seismic codes, component manufacturer's and building construction standards. Whenever a conflict occurs between the manufacturer's or construction standards, the most stringent shall apply.
5. This specification is considered to be minimum requirements for seismic consideration and is not intended as a substitute for legislated, more stringent, national, state or local construction requirements (i.e. California Title 24, California OSHPD, Canadian Building Codes, or other requirements).
6. Any variance or non-compliance with these specification requirements shall be corrected by the contractor in an approved manner.
7. Seismic restraints shall be designed in accordance with seismic force levels as detailed in section 1.0.6.

**B. The work in this section includes, but is not limited to the following:**

1. Vibration isolation for piping, ductwork and equipment.
2. Equipment isolation bases.
3. Flexible piping connections.
4. Seismic restraints for isolated equipment.
5. Seismic restraints for non-isolated equipment.
6. Certification of seismic restraint designs and installation supervision.

7. Certification of seismic attachment of housekeeping pads.
8. All mechanical and electrical systems. Equipment buried underground is excluded but entry of services through the foundation wall is included. Equipment referred to below is typical. (Equipment not listed is still included in this specification).

AC Units	Chillers	Fans (All types)	Tanks (All types)
Air Distrib. Boxes	Compressors	Generators	Transformers
Air Handling Units	Comp. Room Units	Heat Exchangers	Unit Heaters
Air Separators	Condensers	Light Fixtures*	Unit Substations*
Battery Racks*	Condensing Units	Motor Control Ctrs.*	Var. Freq. Drives*
Boilers	Conduit*	Piping	Water Heaters
Bus Ducts*	Cooling Towers	Pumps (All types)	
Cabinet Heaters	Ductwork	Rooftop Units	
Cable Trays*	Electrical Panels	Switch Gear*	

\*Solid Bracing Only

### C. Definitions

#### 1. Life Safety Systems:

- a. All systems involved with fire protection including sprinkler piping, fire pumps, jockey pumps, fire pump control panels, service water supply piping, water tanks, fire dampers and smoke exhaust systems.
- b. All systems involved with and/or connected to emergency power supply including all generators, transfer switches, transformers and all flowpaths to fire protection and/or emergency lighting systems.
- c. All medical and life support systems.
- d. Fresh air relief systems on emergency control sequence including air handlers, conduit, duct, dampers, etc.
- e. All life safety equipment has an asterisk on the equipment schedule.

#### 2. Positive Attachment:

- a. A positive attachment is defined as a cast-in anchor, a drill-in wedge anchor, a double sided beam clamp loaded perpendicular to a beam, or a welded or bolted connection to structure. Single sided "C" type beam clamps for support rods of overhead piping, ductwork, fire protection, electrical conduit, bus duct, or cable trays, or any other equipment are not acceptable on this project as seismic attachment points.

#### 3. Transverse Bracing:

- a. Restraint(s) applied to limit motion perpendicular to the centerline of the pipe, duct or conduit.

4. Longitudinal Bracing:

- a. Restraint(s) applied to limit motion parallel to the centerline of the pipe, duct or conduit.

**1.02 Submittal Data Requirements**

**A.** The manufacturer of vibration isolation and seismic restraints shall provide submittals for products as follows:

1. Descriptive Data:

- a. Catalog cuts or data sheets on vibration isolators and specific restraints detailing compliance with the specification.
- b. Detailed schedules of flexible and rigidly mounted equipment, showing vibration isolators and seismic restraints by referencing numbered descriptive drawings.

2. Shop Drawings:

- a. Submit fabrication details for equipment bases including dimensions, structural member sizes and support point locations.
- b. Provide all details of suspension and support for ceiling suspended equipment.
- c. Where walls, floors, slabs or supplementary steel work are used for seismic restraint locations, details of acceptable attachment methods for ducts, conduit and pipe must be included and approved before the condition is accepted for installation. Restraint manufacturers' submittals must include spacing, static loads and seismic loads at all attachment and support points.
- d. Provide specific details of seismic restraints and anchors; include number, size and locations for each piece of equipment.

3. Seismic Certification and Analysis:

- a. Seismic restraint calculations must be provided for all connections of equipment to the structure. Calculations must be stamped by a registered professional engineer with at least five years of seismic design experience, licensed in the state of the job location.
- b. All restraining devices shall have a preapproval number from California OSHPD or some other recognized government agency showing maximum restraint ratings. Preapprovals based on independent testing are preferred to preapprovals based on calculations. Where preapproved devices are not available, submittals based on independent testing are preferred. Calculations (including the combining of tensile and shear loadings) to support seismic restraint designs must be stamped by a registered professional engineer with at least five years of seismic design experience and licensed in the state of the job location. Testing and calculations must include both shear and tensile loads as well as one test or analysis at 45° to the weakest mode.

- c. Analysis must indicate calculated dead loads, static seismic loads and capacity of materials utilized for connections to equipment and structure. Analysis must detail anchoring methods, bolt diameter, embedment and/or welded length. All seismic restraint devices shall be designed to accept, without failure, the forces detailed in section 1.06 acting through the equipment center of gravity. Overturning moments may exceed forces at ground level.

### **1.03 Code and Standards Requirements**

#### **A. Typical Applicable codes and Standards**

- 1.
2. *To the specifying engineer: Please see section 1.03 Code and Standards Requirements in SVCS-110 Part 1 for applicable codes. You will be referencing one or more codes in 1.03A depending on geographical location. The tables on pages 6, 7 & 8 of SVCS-110 Part 1 may be of value to you.*
- 3.
- 4.
- 5.

### **1.04 Manufacturer's Responsibility**

#### **A. Manufacturer of vibration isolation and seismic control equipment shall have the following responsibilities:**

1. Determine vibration isolation and seismic restraint sizes and locations.
2. Provide vibration isolation and seismic restraints as scheduled or specified.
3. Provide calculations and materials if required for restraint of unisolated equipment.
4. Provide installation instructions, drawings and trained field supervision to insure proper installation and performance.

### **1.05 Related Work**

#### **A. Housekeeping Pads**

1. Housekeeping pad reinforcement and monolithic pad attachment to the structure details and design shall be prepared by the restraint vendor if not already indicated on the drawings.
2. Housekeeping pads shall be coordinated with restraint vendor and sized to provide a minimum edge distance of ten (10) bolt diameters all around the outermost anchor bolt to allow development of full drill-in wedge anchor ratings. If cast-in anchors are to be used, the housekeeping pads shall be sized to accommodate the ACI requirements for bolt coverage and embedment.



**B. Supplementary Support Steel**

1. Contractor shall supply supplementary support steel for all equipment, piping, ductwork, etc. including roof mounted equipment, as required or specified.

**C. Attachments**

1. Contractor shall supply restraint attachment plates cast into housekeeping pads, concrete inserts, double sided beam clamps, etc. in accordance with the requirements of the vibration vendor’s calculations.

**1.06 Seismic Force Levels**

A. The following force levels will be used on this project.

**MINIMUM  $F_p$  (G’s) FORCES EQUAL TO OR EXCEEDING BUILDING CODE LISTED IN 1.03.**

<b><i>IBC-2000</i></b> <b><i>IBC-2003</i></b> <b><i>TI-809-04</i></b> <b><i>NFPA-5000</i></b>  Ss = _____	“G” Forces for High Deformability Pipe, Bus Ducts, Conduits & Cabletrays $a_p^*=1.0, R_p^*=3.5$		“G” Forces for Rigidly Mounted Equipment & Limited Deformability Pipe $a_p^*=1.0, R_p^*=2.5$		“G” Forces for Vibration Isolated Equipment & Pipe Pressure Vessels $a_p^*=2.5, R_p^*=2.5$		“G” Forces for Low Deformability Pipe $a_p^*=1.0, R_p^*=1.25$	
	Horiz.	Vert.	Horiz.	Vert.	Horiz.	Vert.	Horiz.	Vert.
<b>Lower Levels and Ground Level</b>								
<b>Above Ground Level up to 1/4 of the Height of the Building</b>								
<b>Above 1/4 up to 1/2 of the Height of the Building</b>								
<b>Above 1/2 up to 3/4 of the Height of the Building</b>								
<b>Above 3/4 of the Height of the Building up to the Roof</b>								

\*See definitions on page 1, SVCS-110, Part 1.

See instructions on page 5, SVCS-110, Part 1. Add data as required for a particular project. Use only one code per project and add the data on the appropriate line. Codes that are not applicable should be omitted to avoid confusion.

Table 1.06-1

**Part 2 - PRODUCTS**

**2.01 Intent**

- A. All vibration isolators and seismic restraints described in this section shall be the product of a single manufacturer. Mason Industries’ products are the basis of these specifications; products of other manufacturers are acceptable provided their systems strictly comply with the specification and have the approval of the specifying engineer. Submittals and certification sheets shall be in accordance with section 1.02.
- B. For the purposes of this project, failure is defined as the discontinuance of any attachment point between equipment or structure, vertical permanent deformation greater than 1/8” (3mm) and/or horizontal permanent deformation greater that 1/4” (6mm).

**2.02 Product Descriptions**

A. Vibration Isolators and Seismic Restraints.

## SPECIFICATION:

1. Two layers of 3/4" (19mm) thick neoprene pad consisting of 2" (50mm) square waffle modules separated horizontally by a 16 (1.5mm) gauge galvanized shim. Load distribution plates shall be used as required. Pads shall be type **Super "W"** as manufactured by Mason Industries, Inc.
2. Bridge-bearing neoprene mountings shall have a minimum static deflection of 0.2" (5mm) and all directional seismic capability. The mount shall consist of a ductile iron casting containing two separated and opposing molded neoprene elements. The elements shall prevent the central threaded sleeve and attachment bolt from contacting the casting during normal operation. The shock absorbing neoprene materials shall be compounded to bridge-bearing specifications. Mountings shall have an Anchorage Preapproval "OPA" Number from OSHPD in the State of California verifying the maximum certified horizontal and vertical load ratings. Mountings shall be type **BR** as manufactured by Mason Industries, Inc.
3. Sheet metal panels shall be bolted to the walls or supporting structure by assemblies consisting of a neoprene bushing cushioned between 2 steel sleeves. The outer sleeve prevents the sheet metal from cutting into the neoprene. Enlarge panel holes as required. Neoprene elements pass over the bushing to cushion the back panel horizontally. A steel disc covers the inside neoprene element and the inner steel sleeve is elongated to act as a stop so tightening the anchor bolts does not interfere with panel isolation in 3 planes. Bushing assemblies can be applied to the ends of steel cross members where applicable. All neoprene shall be bridge bearing quality. Bushing assemblies shall be type **PB** as manufactured by Mason Industries, Inc.
4. A one piece molded bridge bearing neoprene washer/bushing. The bushing shall surround the anchor bolt and have a flat washer face to avoid metal to metal contact. Neoprene bushings shall be type **HG** as manufactured by Mason Industries, Inc.
5. Spring isolators shall be free standing and laterally stable without any housing and complete with a molded neoprene cup or 1/4" (6mm) neoprene acoustical friction pad between the baseplate and the support. All mountings shall have leveling bolts that must be rigidly bolted to the equipment. Spring diameters shall be no less than 0.8 of the compressed height of the spring at rated load. Springs shall have a minimum additional travel to solid equal to 50% of the rated deflection. Submittals shall include spring diameters, deflection, compressed spring height and solid spring height. Mountings shall be type **SLF** as manufactured by Mason Industries, Inc.
6. Restrained spring mountings shall have an SLF mounting as described in Specification 5, within a rigid housing that includes vertical limit stops to prevent spring extension when weight is removed. The housing shall serve as blocking during erection. Installed and operating heights are equal. A minimum clearance of 1/2" (12mm) shall be maintained around restraining bolts and between the housing and the spring so as not to interfere with the spring action. Restraining Bolts shall have a neoprene bushing between the bolt and the housing. Limit stops shall be out of contact during normal operation. Since housings will be bolted or welded in position there must be an internal isolation pad. Housing shall be designed to resist all seismic forces. Mountings shall have Anchorage Preapproval "OPA" Number from OSHPD in the state of California certifying the maximum certified horizontal and vertical load ratings. Mountings shall be type **SLR** or **SLRS** as manufactured by Mason Industries, Inc.
7. Spring mountings as in specification 5 built into a ductile iron or steel housing to provide all directional seismic snubbing. The snubber shall be adjustable vertically and allow a maximum of 1/4" (6mm) travel in all directions before contacting the resilient snubbing collars. Mountings shall have an Anchorage Preapproval "OPA" number from OSHPD in the State of California

verifying the maximum certified horizontal and vertical load ratings. Mountings shall be type **SSLFH** as manufactured by Mason Industries, Inc.

8. Air Springs shall be manufactured with upper and lower steel sections connected by a replaceable flexible nylon reinforced neoprene element. Air spring configuration shall be multiple bellows to achieve a maximum natural frequency of 3 Hz. Air Springs shall be designed for a burst pressure that is a minimum of three times the published maximum operating pressure. All air spring systems shall be connected to either the building control air or a supplementary air supply and equipped with three leveling valves to maintain leveling within plus or minus 1/8" (3mm). Submittals shall include natural frequency, load and damping tests performed by an independent lab or acoustician. Air Springs shall be type **MT** and leveling valves type **LV** as manufactured by Mason Industries, Inc.
9. Restrained air spring mountings shall have an MT air spring as described in Specification 8, within a rigid housing that includes vertical limit stops to prevent air spring extension when weight is removed. The housing shall serve as blocking during erection. A steel spacer shall be removed after adjustment. Installed and operating heights are equal. A minimum clearance of 1/2" (12mm) shall be maintained around restraining bolts and between the housing and the air spring so as not to interfere with the air spring action. Limit stops shall be out of contact during normal operation. Housing shall be designed to resist all seismic forces. Mountings shall be type **SLR-MT** as manufactured by Mason Industries, Inc.
10. Hangers shall consist of rigid steel frames containing minimum 1 1/4" (32mm) thick neoprene elements at the top and a steel spring with general characteristics as in specification 5 seated in a steel washer reinforced neoprene cup on the bottom. The neoprene element and the cup shall have neoprene bushings projecting through the steel box. To maintain stability the boxes shall not be articulated as clevis hangers nor the neoprene element stacked on top of the spring. Spring diameters and hanger box lower hole sizes shall be large enough to permit the hanger rod to swing through a 30° arc from side to side before contacting the rod bushing and short circuiting the spring. Submittals shall include a hanger drawing showing the 30° capability. Hangers shall be type **30N** as manufactured by Mason Industries, Inc.
- 10A. Hangers shall be as described in 10, but they shall be supplied with a combination rubber and steel rebound washer as the seismic upstop for suspended piping, ductwork, equipment and electrical cabletrays. Rubber thickness shall be a minimum of 1/4" (6mm). Submittals shall include a drawing of the hanger showing the installation of the rebound washer. Hangers shall be type **RW30N** as manufactured by Mason Industries, Inc.
11. Hangers shall be as described in 10, but they shall be precompressed and locked at the rated deflection by means of a resilient seismic upstop to keep the piping or equipment at a fixed elevation during installation. The hangers shall be designed with a release mechanism to free the spring after the installation is complete and the hanger is subjected to its full load. Deflection shall be clearly indicated by means of a scale. Submittals shall include a drawing of the hanger showing the 30° capability. Hangers shall be type **PC30N** as manufactured by Mason Industries, Inc.
12. Seismic Cable Restraints shall consist of galvanized steel aircraft cables sized to resist seismic loads with a minimum safety factor of two and arranged to provide all-directional restraint. Cables must be prestretched to achieve a certified minimum modulus of elasticity. Cable end connections shall be steel assemblies that swivel to final installation angle and utilize two clamping bolts to provide proper cable engagement. Cables must not be allowed

to bend across sharp edges. Cable assemblies shall have an Anchorage Preapproval "OPA" Number from OSHPD in the State of California verifying the maximum certified load ratings. Cable assemblies shall be type **SCB** at the ceiling and at the clevis bolt, **SCBH** between the hanger rod nut and the clevis or **SCBV** if clamped to a beam, all as manufactured by Mason Industries, Inc.

13. Seismic solid braces shall consist of steel angles or channels to resist seismic loads with a minimum safety factor of 2 and arranged to provide all directional restraint. Seismic solid brace end connectors shall be steel assemblies that swivel to the final installation angle and utilize two through bolts to provide proper attachment. Seismic solid brace assembly shall have anchorage preapproval "OPA" number from OSHPD in the state of California verifying the maximum certified load ratings. Solid seismic brace assemblies shall be type **SSB**, **SSBS** or **SSRF** as manufactured by Mason Industries, Inc.

Note: Specifications 12 - 14 apply to trapeze as well as clevis hanger locations. At trapeze anchor locations piping must be shackled to the trapeze. Specifications apply to hanging equipment as well.

14. Steel angles, sized to prevent buckling, shall be clamped to pipe or equipment rods utilizing a minimum of three ductile iron clamps at each restraint location when required. Welding of support rods is not acceptable. Rod clamp assemblies shall have an Anchorage Preapproval "OPA" Number from OSHPD in the State of California. Rod clamp assemblies shall be type **SRC** or **UC** as manufactured by Mason Industries, Inc.
15. Pipe clevis cross bolt braces are required in all restraint locations. They shall be special purpose preformed channels deep enough to be held in place by bolts passing over the cross bolt. Clevis cross braces shall have an Anchorage Preapproval "OPA" Number from OSHPD in the State of California. Clevis cross brace shall be type **CCB** as manufactured by Mason Industries, Inc.
16. All-directional seismic snubbers shall consist of interlocking steel members restrained by a one-piece molded neoprene bushing of bridge bearing neoprene. Bushing shall be replaceable and a minimum of 1/4" (6mm) thick. Rated loadings shall not exceed 1000 psi (.7kg/mm<sup>2</sup>). A minimum air gap of 1/8" (3mm) shall be incorporated in the snubber design in all directions before contact is made between the rigid and resilient surfaces. Snubber end caps shall be removable to allow inspection of internal clearances. Neoprene bushings shall be rotated to insure no short circuits exist before systems are activated. Snubbers shall have an Anchorage Preapproval "OPA" Number from OSHPD in the State of California verifying the maximum certified horizontal and vertical load ratings. Snubber shall be type **Z-1225** as manufactured by Mason Industries, Inc.
17. All directional seismic snubbers shall consist of interlocking steel members restrained by shock absorbent rubber materials compounded to bridge bearing specifications. Elastomeric materials shall be replaceable and a minimum of 3/4" (19mm) thick. Rated loadings shall not exceed 1000 psi (.7kg/mm<sup>2</sup>). Snubbers shall be manufactured with an air gap between hard and resilient material of not less than 1/8" (3mm) nor more than 1/4" (6mm). Snubbers shall be installed with factory set clearances. The capacity of the seismic snubber at 3/8" (9mm) deflection shall be equal or greater than the load assigned to the mounting grouping controlled by the snubber multiplied by the applicable "G" force. Submittals shall include the load

deflection curves up to 1/2" (12mm) deflection in the x, y and z planes. Snubbers shall have an anchorage preapproval "OPA" number from OSHPD in the state of California verifying the maximum certified horizontal and vertical load ratings. Snubbers shall be type **Z-1011** as manufactured by Mason Industries, Inc.

18. Stud wedge anchors shall be manufactured from full diameter wire, not from undersized wire that is "rolled up" to create the thread. The stud anchor shall also have a safety shoulder which fully supports the wedge ring under load. The stud anchors shall have an evaluation report number from the I.C.B.O Evaluation Service, Inc. verifying its allowable loads. Drill-in stud wedge anchors shall be type **SAS** as manufactured by Mason Industries, Inc.
19. Female wedge anchors are preferred in floor locations so isolators or equipment can be slid into place after the anchors are installed. Anchors shall be manufactured from full diameter wire, and shall have a safety shoulder to fully support the wedge ring under load. Female wedge anchors shall have an evaluation report number from the I.C.B.O Evaluation Service, Inc. verifying to its allowable loads. Drill-in female wedge anchors shall be type **SAB** as manufactured by Mason Industries, Inc.
20. Vibration isolation manufacturer shall furnish integral structural steel bases. Rectangular bases are preferred for all equipment. Centrifugal refrigeration machines and pump bases may be T or L shaped where space is a problem. Pump bases for split case pump shall include supports for suction and discharge elbows. All perimeter members shall be steel beams with a minimum depth equal to 1/10 of the longest dimension of the base. Base depth need not exceed 14" (350mm) provided that the deflection and misalignment is kept within acceptable limits as determined by the manufacturer. Height saving brackets shall be employed in all mounting locations to provide a base clearance of 1" (25mm). Bases shall be type **WF** as manufactured by Mason Industries, Inc.
21. Vibration isolation manufacturer shall furnish rectangular steel concrete pouring forms for floating and inertia foundations. Bases for split case pumps shall be large enough to provide for suction and discharge elbows. Bases shall be a minimum of 1/12 of the longest dimension of the base but not less than 6" (150mm). The base depth need not exceed 12" (300mm) unless specifically recommended by the base manufacturer for mass or rigidity. Forms shall include minimum concrete reinforcing consisting of 1/2" (12mm) bars welded in place on 6" (150mm) centers running both ways in a layer 1 1/2" (38mm) above the bottom. Forms shall be furnished with steel templates to hold the anchor bolts sleeves and anchors while concrete is being poured. Height saving brackets shall be employed in all mounting locations to maintain a 1" (25mm) clearance below the base. Wooden formed bases leaving a concrete rather than a steel finish are not acceptable. Base shall be type **BMK** or **K** as manufactured by Mason Industries, Inc.
22. Curb mounted rooftop equipment shall be mounted on spring isolation curbs. The lower member shall consist of a sheet metal or structural steel sections containing adjustable and removable steel springs that support the upper floating section. The upper frame must provide continuous support for the equipment and must be captive so as to resiliently resist wind and seismic forces. All directional neoprene snubber bushings shall be a minimum of 1/4" (6mm) thick. Steel springs shall be laterally stable and rest on 1/4" (6mm) thick neoprene acoustical pads. Hardware must be plated and the springs provided with a rust resistant finish. The curbs waterproofing shall consist of a continuous flexible flashing nailed over the lower curbs waterproofing. All spring locations shall have accessibility to adjust springs.



Lower curbs shall have provision for 2" (50mm) of insulation. The roof curbs shall be built to seismically contain the rooftop unit. The unit must be solidly fastened to the top floating rail, and the lower section anchored to the roof structure. Curb shall have anchorage pre-approval "OPA" from OSHPD in the state of California attesting to the maximum certified horizontal and vertical load ratings. Curb shall be type **SRSC** or **RMSS** as manufactured by Mason Industries, Inc.

23. Flexible spherical expansion joints shall employ peroxide cured EPDM in the covers, liners and Kevlar® tire cord frictioning. Any substitutions must have equal or superior physical and chemical characteristics. Solid steel rings shall be used within the raised face rubber flanged ends to prevent pullout. Flexible cable bead wire is not acceptable. Sizes 2" (50mm) and larger shall have two spheres reinforced with a ductile iron external ring between spheres. Flanges shall be split ductile iron or steel with hooked or similar interlocks. Sizes 16" (400mm) to 24" (600mm) may be single sphere. Sizes 3/4" (19mm) to 1 1/2" (38mm) may have threaded two piece bolted flange assemblies, one sphere and cable retention. Connectors shall be rated at 250 psi (1.72MPa) up to 170°F (77°C) with a uniform drop in allowable pressure to 215 psi (1.48MPa) at 250°F (121°C) in sizes through 14" (350mm). 16" (400mm) through 24" (600mm) single sphere minimum ratings are 180 psi (1.24MPa) at 170°F (77°C) and 150 psi (1.03MPa) at 250°F (121°C). Higher rated connectors may be used to accommodate service conditions. All expansion joints must be factory tested to 150% of rated pressure for 12 minutes before shipment. Safety factors to burst and flange pullout shall be a minimum of 3/1. Concentric reducers to the above ratings may be substituted for equal ended expansion joints.

Expansion joints shall be installed in piping gaps equal to the length of the expansion joints under pressure. Control rods need only be used in unanchored piping locations where the manufacturer determines the installation exceeds the pressure requirement without control rods. If control rods are used, they must have 1/2" (12mm) thick Neoprene washer bushings large enough in diameter to take the thrust at 1000 psi (.7 kg/mm²) maximum on the washer area.

Submittals shall include two test reports by independent consultants showing minimum reductions of 20 DB in vibration accelerations and 10 DB in sound pressure levels at typical blade passage frequencies on this or a similar product by the same manufacturer. All expansion joints shall be installed on the equipment side of the shut off valves. Expansion joints shall be type **SAFEFLEX SFDEJ, SFEJ, SFDCR** or **SFU** and Control Rods **CR** as manufactured by Mason Industries, Inc.

24. Flexible stainless steel hose shall have stainless steel braid and carbon steel fittings. Sizes 3" (75mm) and larger shall be flanged. Smaller sizes shall have male nipples. Minimum lengths shall be as tabulated:

Flanged

3" x 14" (75 x 350mm)	6" x 20" (150 x 500mm)	12" x 28" (300 x 700mm)
4" x 15" (100 x 375mm)	8" x 22" (200 x 550mm)	14" x 30" (350 x 750mm)
5" x 19" (125 x 475mm)	10" x 26" (250 x 650mm)	16" x 32" (400 x 800mm)

Male Nipples

1/2" x 9" (12 x 225mm)	1 1/4" x 12" (32 x 300mm)	2" x 14" (50 x 350mm)
3/4" x 10" (19 x 250mm)	1 1/2" x 13" (38 x 325mm)	2 1/2" x 18" (64 x 450mm)
1" x 11" (25 x 275mm)		

Hoses shall be installed on the equipment side of the shut-off valves horizontally and paral-

labeled to the equipment shafts wherever possible. Hoses shall be type **BSS** as manufactured by Mason Industries, Inc.

25. All-directional acoustical pipe anchor, consisting of two sizes of steel tubing separated by a minimum 1/2" (12mm) thick 60 durometer neoprene. Vertical restraint shall be provided by similar material arranged to prevent vertical travel in either direction. Allowable loads on the isolation material should not exceed 500 psi (.35 kg/mm<sup>2</sup>) and the design shall be balanced for equal resistance in any direction. All-directional anchors shall be type **ADA** as manufactured by Mason Industries, Inc.
26. Pipe guides shall consist of a telescopic arrangement of two sizes of steel tubing separated by a minimum 1/2" (12mm) thickness of 60 durometer neoprene. The height of the guides shall be preset with a shear pin to allow vertical motion due to pipe expansion or contraction. Shear pin shall be removable and reinsertable to allow for selection of pipe movement. Guides shall be capable of ±15/8" (41mm) motion, or to meet location requirements. Pipe guides shall be type **VSG** as manufactured by Mason Industries, Inc.
27. Split Wall Seals consist of two bolted pipe halves with minimum 3/4" (19mm) thick neoprene sponge bonded to the inner faces. The seal shall be tightened around the pipe to eliminate clearance between the inner sponge face and the piping. Concrete may be packed around the seal to make it integral with the floor, wall or ceiling if the seal is not already in place around the pipe prior to the construction of the building member. Seals shall project a minimum of 1" (25mm) past either face of the wall. Where temperatures exceed 240°F(115°C), 10# (4.5kg) density fiberglass may be used in lieu of the sponge. Seals shall be type **SWS** as manufactured by Mason Industries, Inc.
28. The horizontal thrust restraint shall consist of a spring element in series with a neoprene molded cup as described in specification 5 with the same deflection as specified for the mountings or hangers. The spring element shall be designed so it can be preset for thrust at the factory and adjusted in the field to allow for a maximum of 1/4" (6mm) movement at start and stop. The assembly shall be furnished with 1 rod and angle brackets for attachment to both the equipment and the ductwork or the equipment and the structure. Horizontal restraints shall be attached at the centerline of thrust and symmetrical on either side of the unit. Horizontal thrust restraints shall be type **WBI/WBD** as manufactured by Mason Industries, Inc.
29. Housekeeping pad anchors shall consist of a ductile iron casting that is tapered and hexagonal, smaller at its base than at its top. The upper portion shall have holes for rebar to pass through. The anchor shall be continuously threaded from top to bottom for the attachment of soleplates. Housekeeping pad anchors shall be attached to the structural slab using a stud wedge anchor. Housekeeping pad anchors shall be type **HPA** and stud wedge anchor shall be type **SAS** both as manufactured by Mason Industries, Inc.

### Part 3 - EXECUTION

#### 3.01 General

- A. All vibration isolators and seismic restraint systems must be installed in strict accordance with the manufacturers written instructions and all certified submittal data.

- B.** Installation of vibration isolators and seismic restraints must not cause any change of position of equipment, piping or ductwork resulting in stresses or misalignment.
- C.** No rigid connections between equipment and the building structure shall be made that degrades the noise and vibration control system herein specified.
- D.** The contractor shall not install any equipment, piping, duct or conduit which makes rigid connections with the building unless isolation is not specified. "Building" includes, but is not limited to, slabs, beams, columns, studs and walls.
- E.** Coordinate work with other trades to avoid rigid contact with the building.
- F.** Any conflicts with other trades which will result in rigid contact with equipment or piping due to inadequate space or other unforeseen conditions should be brought to the architects/engineers attention prior to installation. Corrective work necessitated by conflicts after installation shall be at the responsible contractors expense.
- G.** Bring to the architects/engineers attention any discrepancies between the specifications and the field conditions or changes required due to specific equipment selection, prior to installation. Corrective work necessitated by discrepancies after installation shall be at the responsible contractors expense.
- H.** Correct, at no additional cost, all installations which are deemed defective in workmanship and materials at the contractors expense.
- I.** Overstressing of the building structure must not occur because of overhead support of equipment. Contractor must submit loads to the structural engineer of record for approval. Generally bracing may occur from:
  - a. Flanges of structural beams.
  - b. Upper truss cords in bar joist construction.
  - c. Cast in place inserts or wedge type drill-in concrete anchors.
- J.** Specification 12 cable restraints shall be installed slightly slack to avoid short circuiting the isolated suspended equipment, piping or conduit.
- K.** Specification 12 cable assemblies are installed taut on non-isolated systems. Specification 13 seismic solid braces may be used in place of cables on rigidly attached systems only.
- L.** At locations where specification 12 or 13 restraints are located, the support rods must be braced when necessary to accept compressive loads with specification 14 braces.
- M.** At locations where specification 12 cable restraints are installed on support rods with spring isolators, the spring isolation hangers must be specification type 10A.
- N.** At all locations where specification 12 or 13 restraints are attached to pipe clevis's, the clevis cross bolt must be reinforced with specification type 15 braces.
- O.** Drill-in concrete anchors for ceiling and wall installation shall be specification type 18, and specification type 19 female wedge type for floor mounted equipment.
- P.** Vibration isolation manufacturer shall furnish integral structural steel bases as required. Independent steel rails are not permitted on this project.



- Q. Hand built elastomeric expansion joints may be used when pipe sizes exceed 24" or specified movements exceed specification 23 capabilities.
- R. Where piping passes through walls, floors or ceilings the vibration isolation manufacturer shall provide specification 27 wall seals.
- S. Air handling equipment and centrifugal fans shall be protected against excessive displacement which results from high air thrust in relation to the equipment weight. Horizontal thrust restraint shall be specification type 28 (see selection guide).
- T. Locate isolation hangers as near to the overhead support structure as possible.
- U. All fire protection piping shall be braced in accordance with NFPA 13 and 14.
- V. All mechanical equipment shall be vibration isolated and seismically restrained as per the schedules in part 4 of this specification.
- W. All fire protection equipment is considered life safety equipment and shall be seismically restrained using the seismic force levels for life safety equipment in table 1.06-1, if higher levels are shown.
- X. VAV boxes and fan powered equipment weighing less than 50 lbs. (23kg) and rigidly connected to the supply side of the duct system and supported with a minimum of 4 hanger rods.

### **3.02 Vibration Isolation of Piping**

- A. Horizontal pipe isolation: The first four pipe hangers in the main lines near the mechanical equipment shall be as described in specification 11. Brace hanger rods with SRC clamps specification 14. Horizontal runs in all other locations throughout the building shall be isolated by hangers as described in specification 10 & 10A. Floor supported piping shall rest on isolators as described in specification 6. Heat exchangers and expansion tanks are considered part of the piping run. The first three isolators from the isolated equipment will have the same static deflection as specified for the mountings under the connected equipment. If piping is connected to equipment located in basements and hangs from ceilings under occupied spaces the first three hangers shall have 0.75" (19mm) deflection for pipe sizes up to and including 3" (75mm), 1 1/2" (38mm) deflection for pipe sizes up to and including 6" (150mm), and 2 1/2" (64mm) deflection thereafter. Hangers shall be located as close to the overhead structure as practical. Hanger locations that also have seismic restraints attached must have type RW Rebound Washers to limit uplift. Where piping connects to mechanical equipment install specification 23 expansion joints or specification 24 stainless hoses if 23 is not suitable for the service.
- B. Riser isolation: Risers shall be suspended from specification 10A hangers or supported by specification 5 mountings, anchored with specification 25 anchors, and guided with specification 26 sliding guides. Steel springs shall be a minimum of 0.75" (19mm) except in those expansion locations where additional deflection is required to limit load changes to  $\pm 25\%$  of the initial load. Submittals must include riser diagrams and calculations showing anticipated expansion and contraction at each support point, initial and final loads on the building structure, spring deflection changes and seismic loads. Submittal data shall include certification that the riser system has been examined for excessive stresses and that none will exist in the proposed design.
- C. Seismic Restraint of Piping

1. Seismically restrain all piping listed as a, b or c below. Use specification 12 cables if isolated. Specification 12 or 13 restraints may be used on unisolated piping.
  - a. Fuel oil piping, gas piping, medical gas piping, and compressed air piping that is 1" (25mm) I.D. or larger.
  - b. Piping located in boiler rooms, mechanical equipment rooms, and refrigeration equipment rooms that is 1 1/4" (32mm) I.D. and larger.
  - c. All other piping 2 1/2" (64mm) diameter and larger.
2. Transverse piping restraints shall be at 40' (12m) maximum spacing for all pipe sizes, except where lesser spacing is required to limit anchorage loads.
3. Longitudinal restraints shall be at 80' (24m) maximum spacing for all pipe sizes, except where lesser spacing is required to limit anchorage loads.
4. Where thermal expansion is a consideration, guides and anchors may be used as transverse and longitudinal restraints provided they have a capacity equal to or greater than the restraint loads in addition to the loads induced by expansion or contraction.
5. For fuel oil and all gas piping transverse restraints must be at 20' (6m) maximum and longitudinal restraints at 40' (12m) maximum spacing.
6. Transverse restraint for one pipe section may also act as a longitudinal restraint for a pipe section of the same size connected perpendicular to it if the restraint is installed within 24" (600mm) of the elbow or TEE or combined stresses are within allowable limits at longer distances.
7. Hold down clamps must be used to attach pipe to all trapeze members before applying restraints in a manner similar to clevis supports.
8. Branch lines may not be used to restrain main lines.
9. Cast iron pipe of all types, glass pipe and any other pipes joined with a four band shield and clamp assembly in areas with Ss of 0.35 or greater shall be braced as in sections 3.02.C.2 and 3. For areas with Ss less than 0.35, 2 band clamps may be used with a reduced spacing of 1/2 of those listed in sections 3.02.C.2 and 3.
10. Connection to the structure must be made with a non-friction connection (i.e. no "C" clamps)
11. Hanger locations that also have seismic restraints attached must have Specification 10A type RW Rebound Washers.

**D. Pipe Exclusions**

1. Gas piping less than 1" (25mm) inside diameter.
2. Piping in boiler and mechanical rooms less than 1 1/4" (32mm) inside diameter.
3. All other piping less than 2 1/2" (64mm) inside diameter.
4. a. All piping suspended by clevis hangers where the distance from the top of the pipe to the suspension point is 12" or less.

- b. All trapezed piping where the distance from the suspension point to the trapeze member is 12" or less.
- c. If any suspension location in the run exceeds the above, the entire run must be braced.

### **3.03 Vibration Isolation and Seismic Restraint of Ductwork**

#### **A. Vibration isolation of ductwork**

- 1. All discharge runs for a distance of 50' (15m) from the connected equipment shall be isolated from the building structure by means of specification 10 hangers or specification 5 floor isolators. Spring deflection shall be a minimum of 0.75" (19mm).
- 2. All duct runs having air velocity of 1000 fpm (5 m/s) or more shall be isolated from the building structure by specification 11 hangers or 5 floor supports. Spring deflection shall be a minimum of 0.75" (19mm).

#### **B. Seismic restraint of ductwork**

- 1. Seismically restrain all ductwork with specification 12 or 13 restraints as listed below:
  - a. Restrain rectangular ducts with cross sectional area of 6 sq.ft. (.5 m<sup>2</sup>) or larger.
  - b. Restrain round ducts with diameters of 28" (700mm) or larger.
  - c. Restrain flat oval ducts the same as rectangular ducts of the same nominal size.
- 2. Transverse restraints shall occur at 30' (9m) intervals or at both ends of the duct run if less than the specified interval. Transverse restraints shall be installed at each duct turn and at each end of a duct run.
- 3. Longitudinal restraints shall occur at 60' (18m) intervals with at least one restraint per duct run. Transverse restraints for one duct section may also act as a longitudinal restraint for a duct section connected perpendicular to it if the restraints are installed within 4' (1.2m) of the intersection of the ducts and if the restraints are sized for the larger duct. Duct joints shall conform to SMACNA duct construction standards.
- 4. The ductwork must be reinforced at the restraint locations. Reinforcement shall consist of an additional angle on top of the ductwork that is attached to the support hanger rods. Ductwork is to be attached to both upper angle and lower trapeze.
- 5. A group of ducts may be combined in a larger frame so that the combined weights and dimensions of the ducts are less than or equal to the maximum weight and dimensions of the duct for which bracing details are selected.
- 6. Walls, including gypsum board non bearing partitions, which have ducts running through them may replace a typical transverse brace. Provide channel framing around ducts and solid blocking between the duct and frame.
- 7. Connection to the structure must be made with a non-friction connection (i.e. no "C" clamps)
- 8. Hanger locations that also have seismic restraints attached must have Specification 10A type RW Rebound Washers.

### **C. Ductwork Exclusions**

1. Rectangular and square and ducts that are less than 6 square feet in cross sectional area.
2. Oval ducts that are less than 6 square feet (.5m<sup>2</sup>) in cross sectional area based on nominal size.
3. Round duct less than 28" (.5m<sup>2</sup>) in diameter.
4.
  - a. All trapezed ductwork where the distance from the suspension point to the trapeze member is 12" or less.
  - b. Ductwork hung with straps where the top of the duct is 12" or less from the suspension point and the strap has 2 #10 sheet metal screws within 2" of the top of the duct.
  - c. If any suspension location in the run exceeds the above, the entire run must be braced.

### **3.04 Electrical Services**

#### **A. Seismic Restraint**

1. All electrical conduit 2 1/2" (64mm) in diameter and larger shall be restrained with specification type 12 seismic cable restraints or specification type 13 for seismic solid brace restraints.
2. All electrical bus ducts, cable trays and ladder trays shall be restrained with specification type 12, seismic cable restraints or specification 13 seismic solid brace restraints.
3. Transverse restraints shall occur at 30' (9m) intervals or both ends if the electrical run is less than the specified interval. Transverse restraints shall be installed at each electrical services turn and at each end of the electric run.
4. Longitudinal restraints shall occur at 60' (18m) intervals with at least one restraint per electric run. Transverse restraints for one electric section may also act as a longitudinal restraint for a duct for an electric section connected perpendicular to it if the restraints are installed within 4' (1.2m) of the intersection of the electric run and if the restraints are sized for the larger electric run.
5. All floor mounted transformers, motor starters, switchgears and substations must have a resilient media between the equipment mounting hole and the anchor bolt. Anchor bolts shall be designed in accordance with section 1.06 seismic forces. Neoprene bushings shall be specification type 4 and anchor bolts shall be specification type 18 or 19.
6. Wall mounted panels, transformers and motor starters shall be mounted with specification type 3 bushings. Floor mounted panels shall be mounted on specification type 4 bushings. Anchor bolts shall be specification type 18 or 19.
7. All generators shall be mounted on a Specification type 21 concrete inertia base, with Specification type 5 spring isolators and Specification type 17 seismic snubbers.
8. Connection to the structure must be made with a non-friction connection (i.e. no "C" clamps)

#### **B. Exclusions**

1. All conduit less than 2 1/2" (64mm) diameter suspended by individual hanger rods.

2. a. All conduits suspended by clevis hangers where the distance from the top of the pipe to the suspension point is 12" or less.
- b. All trapezed conduits, bus ducts and cable trays where the distance from the suspension point to the trapeze member is 12" or less.
- c. If any suspension location in the run exceeds the above, the entire run must be braced.

**Part 4 - SCHEDULES**

**4.01 Equipment Isolator and Seismic Restraint Schedule**

See General Instructions, page 3, SVCS-110 Part 1.

Equipment Schedule	Vibration Isolation and/or Seismic Restraint	
	Specification	Static Deflection

**SPECIFICATION PRODUCT DETAILS**

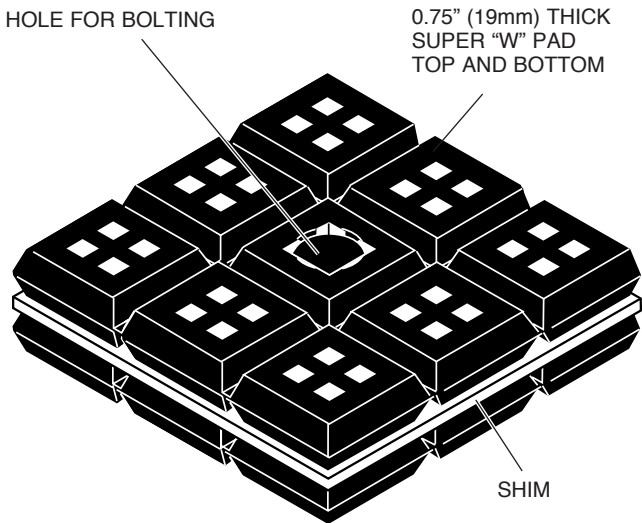
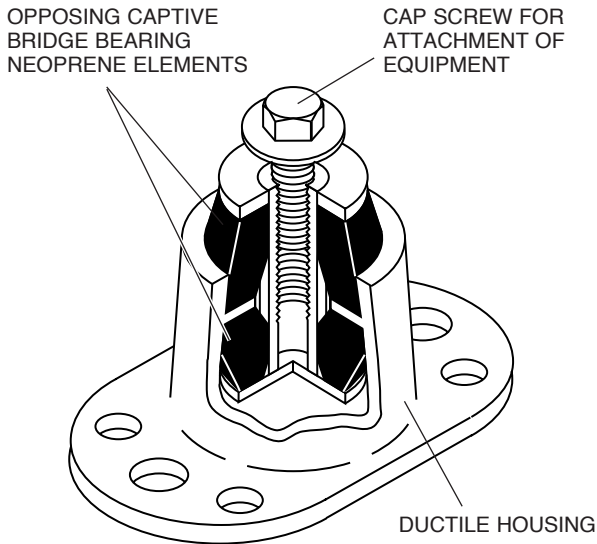
 <p style="text-align: center;">LAYERED SUPER "W" PADS WITH STEEL SHIM SPECIFICATION 1</p>	 <p style="text-align: center;">RESTRAINED BR MOUNT OSHPD PRE-APPROVAL OPA-201 SPECIFICATION 2</p>
---	--

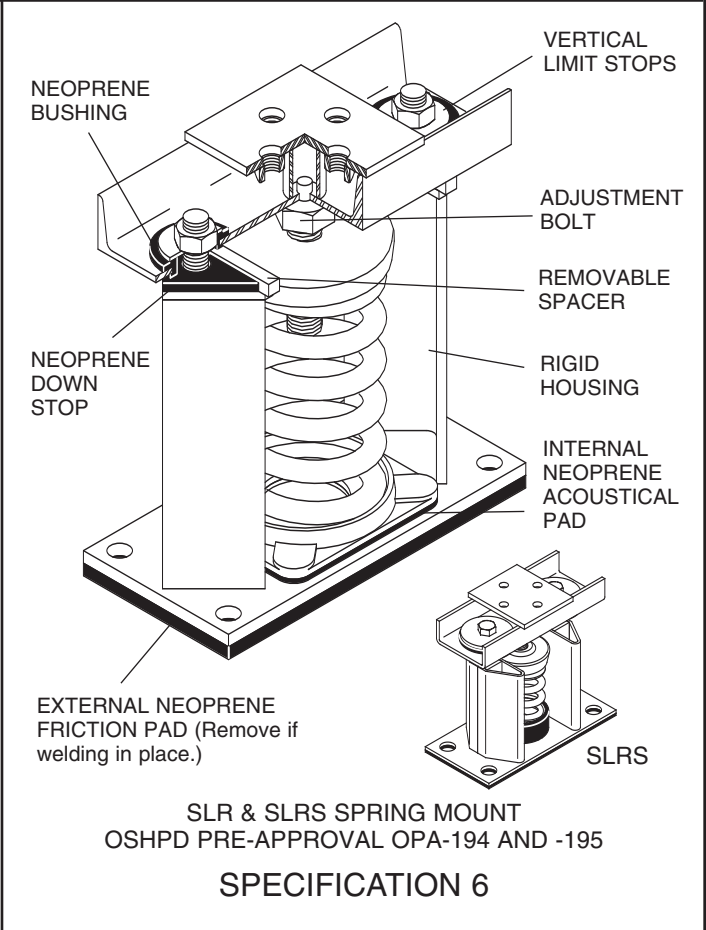
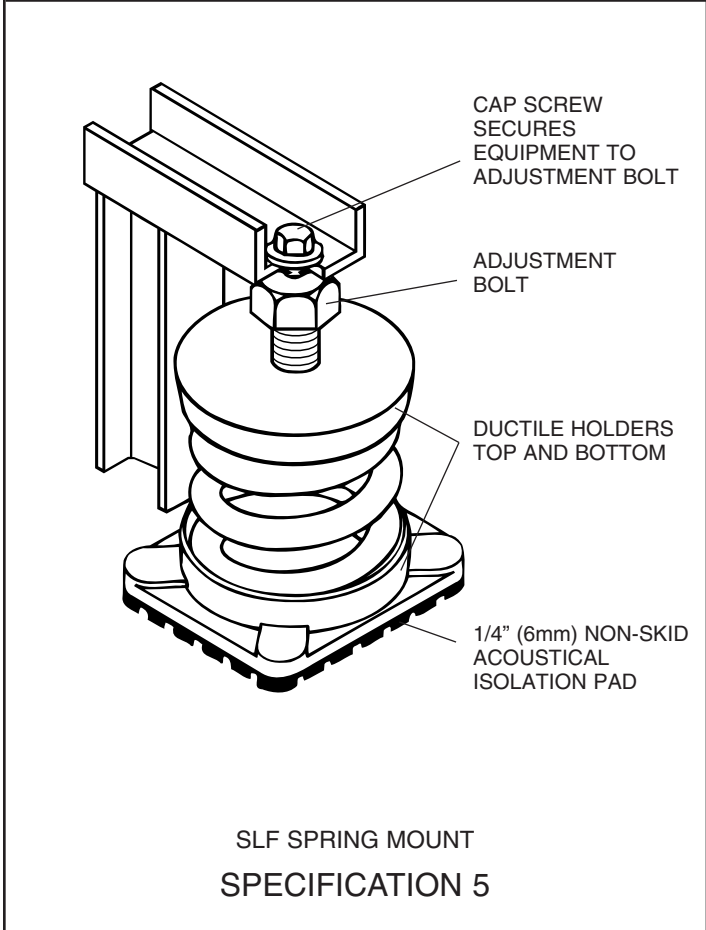
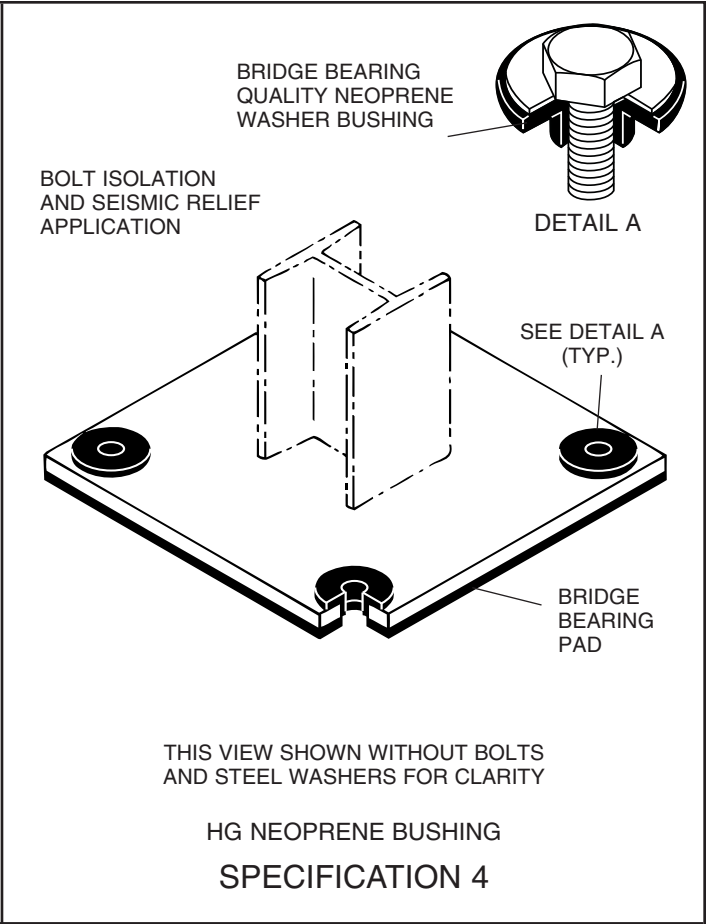
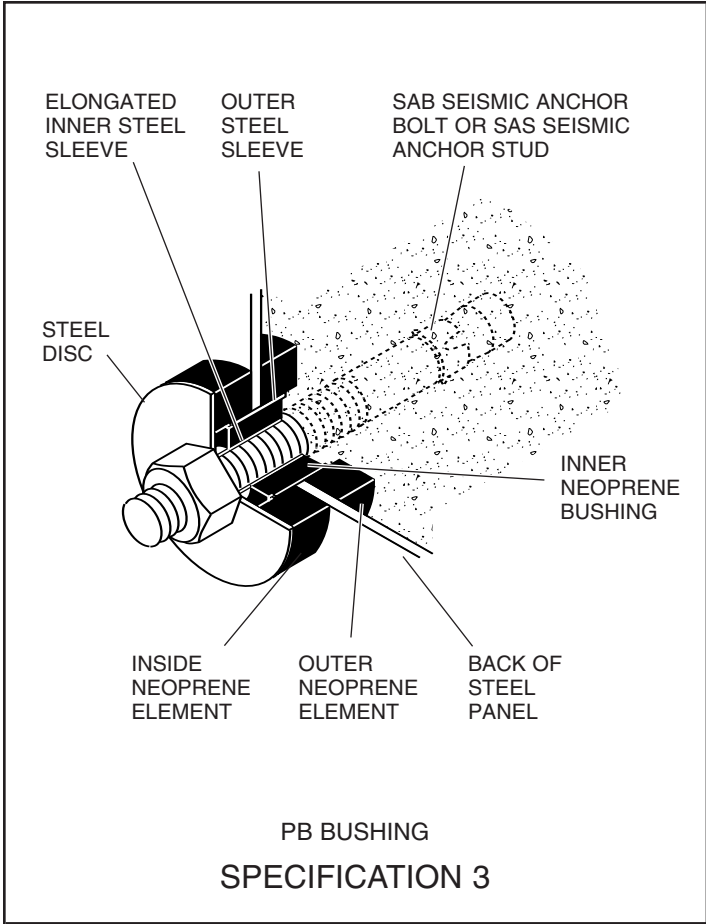

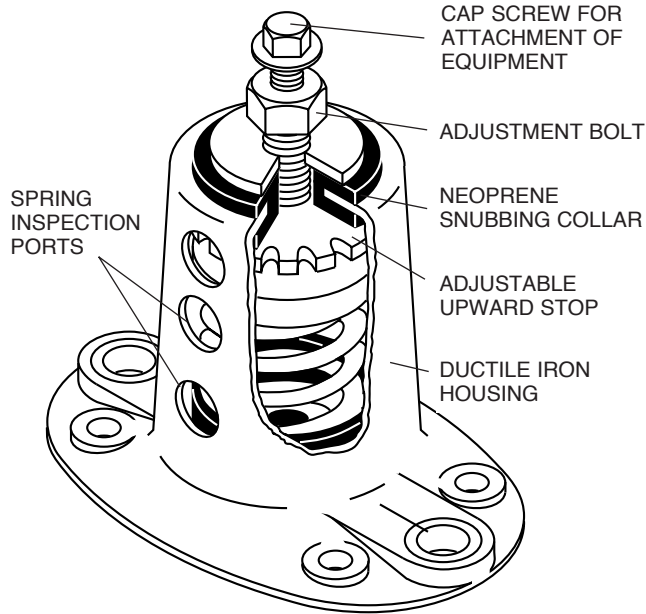

SSLFH HOUSED SPRING MOUNT  
OSHPD PRE-APPROVAL OPA-198 AND -199  
SPECIFICATION 7

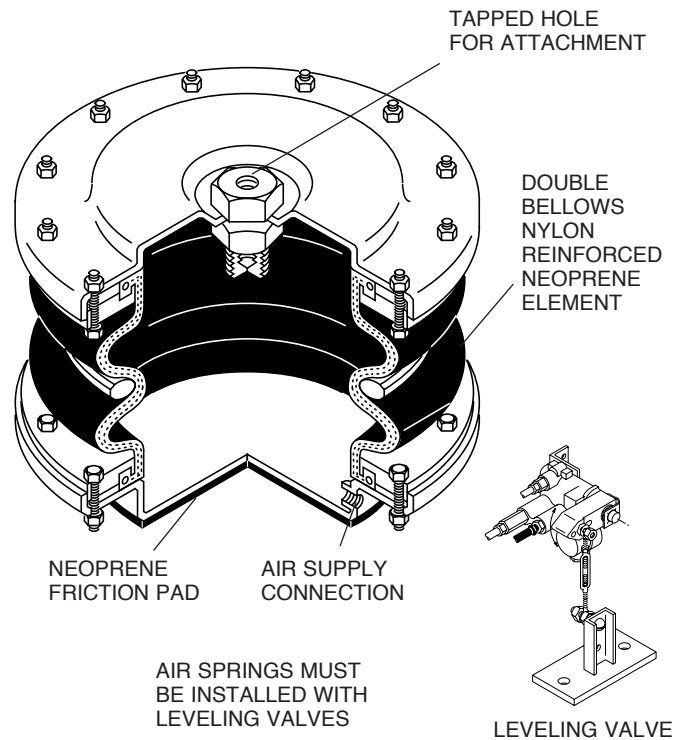

MT AIR SPRING MOUNT  
SPECIFICATION 8

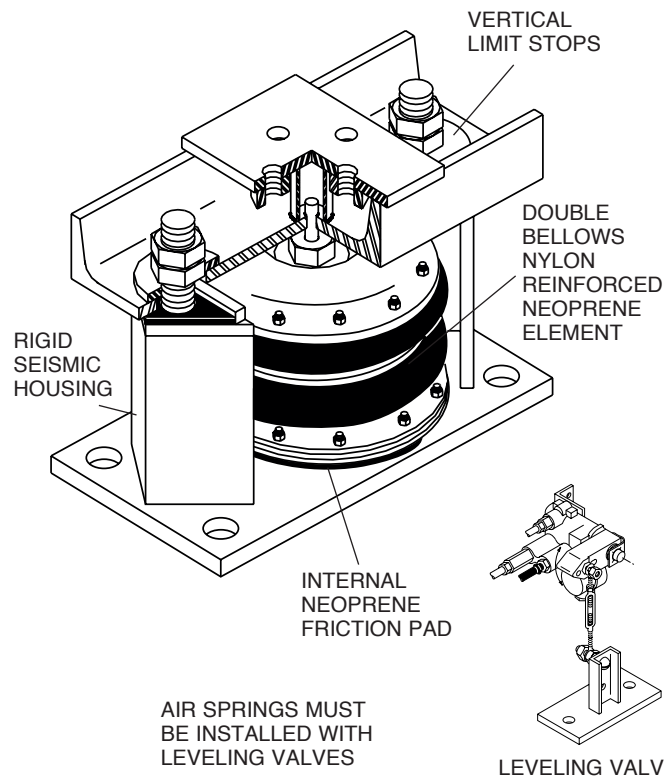

SLR AIR SPRING MOUNT  
SPECIFICATION 9

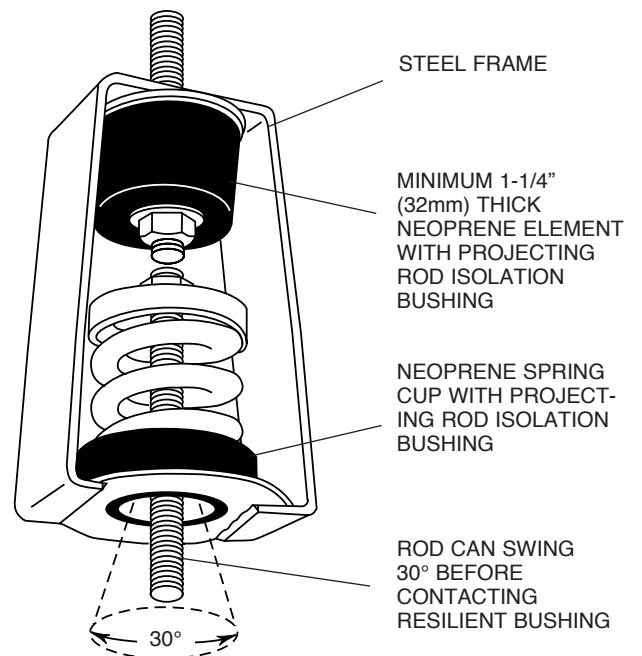

30N SPRING AND NEOPRENE HANGER  
SPECIFICATION 10



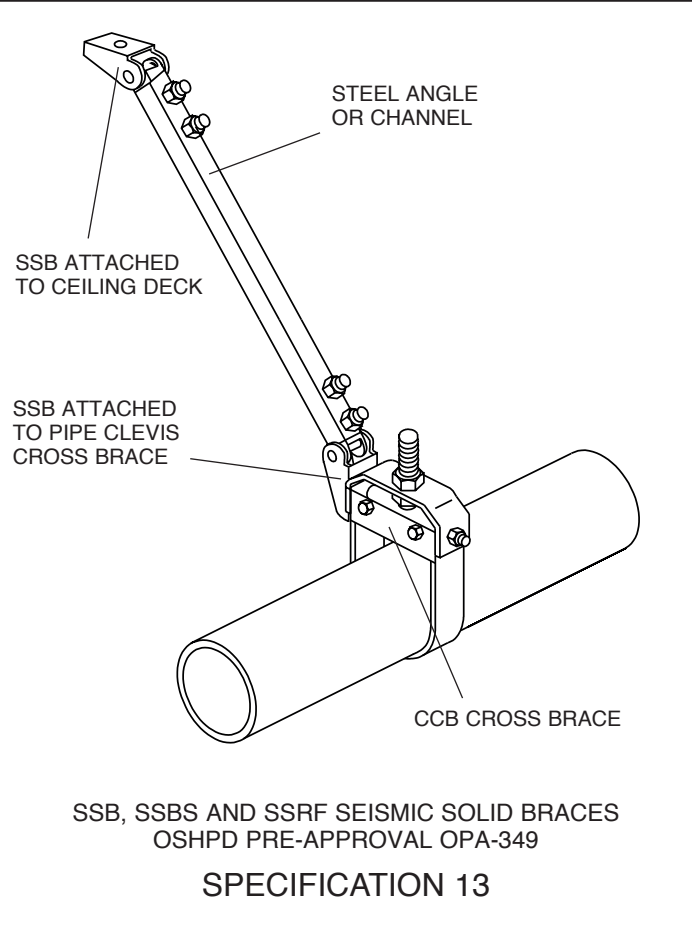
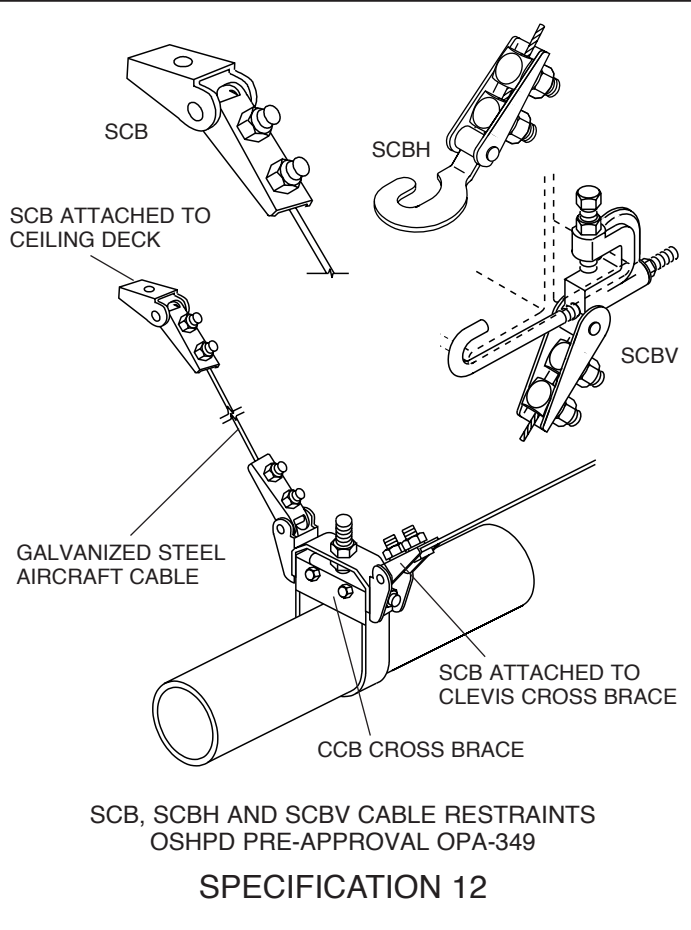
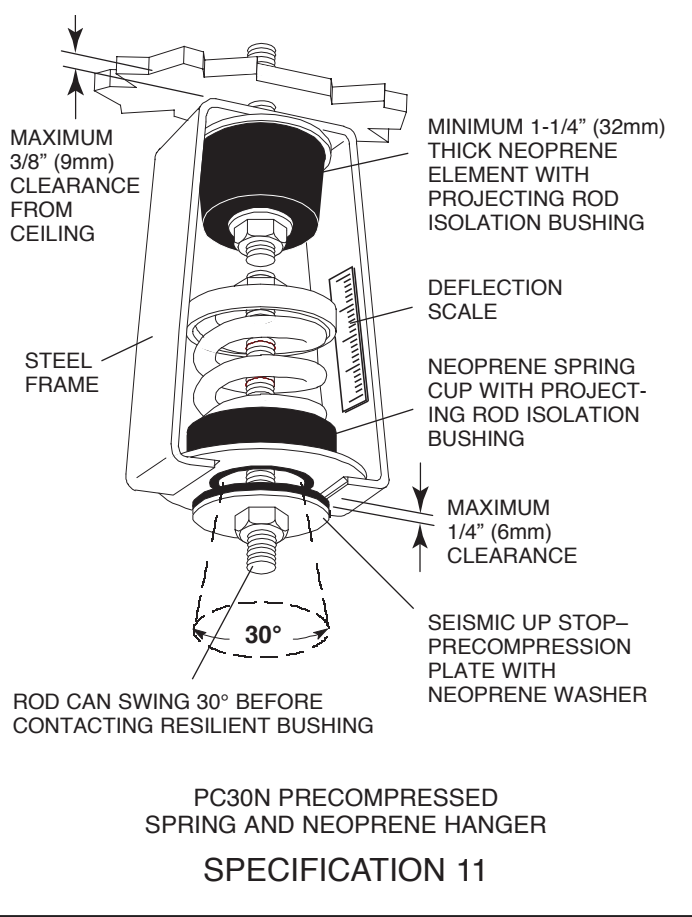
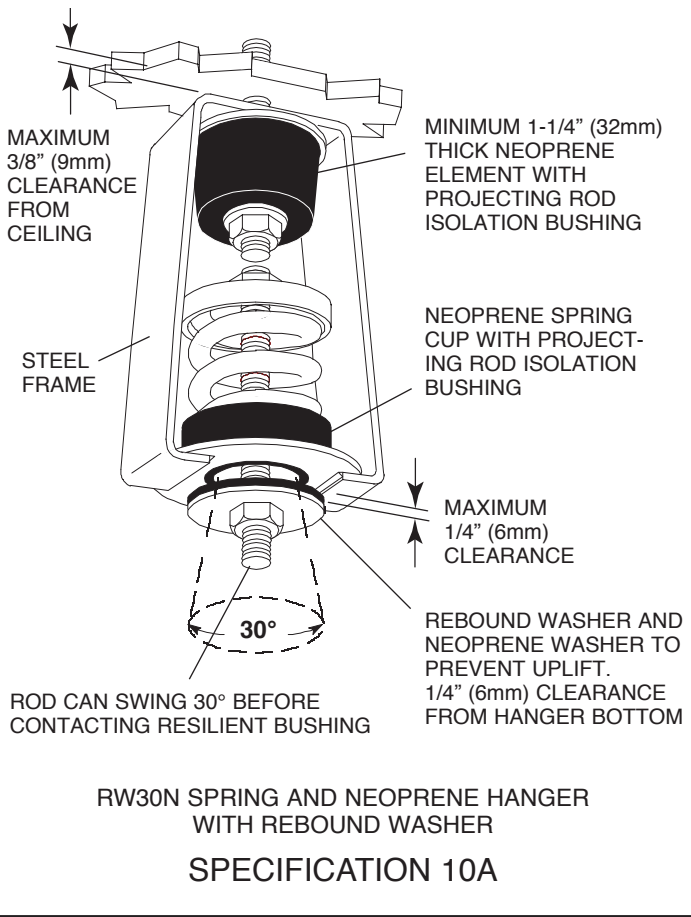



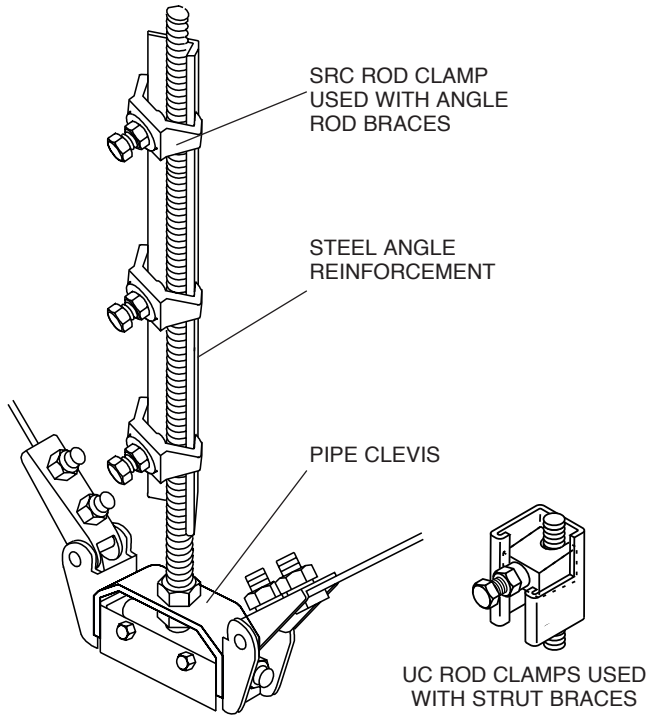

SRC AND UC SEISMIC ROD CLAMPS  
OSHPD PRE-APPROVAL OPA-349

**SPECIFICATION 14**

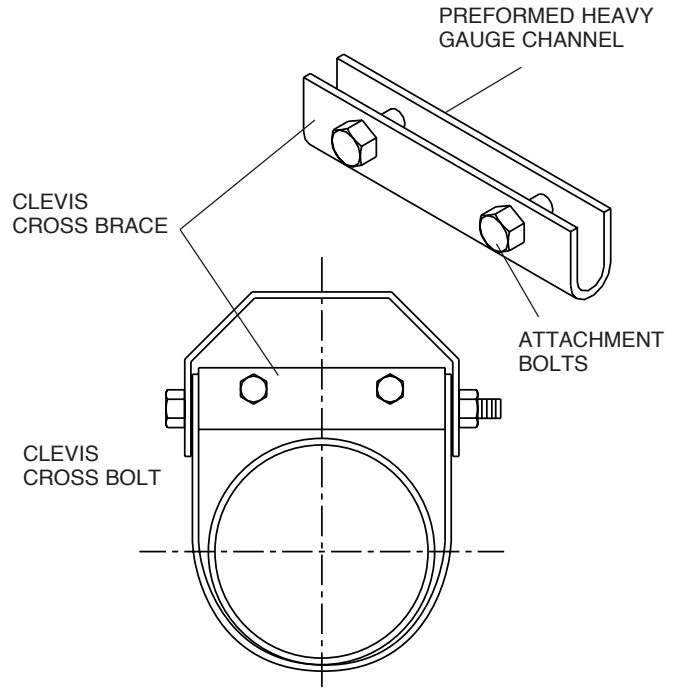

CCB CLEVIS CROSS BRACE  
OSHPD PRE-APPROVAL OPA-349

**SPECIFICATION 15**

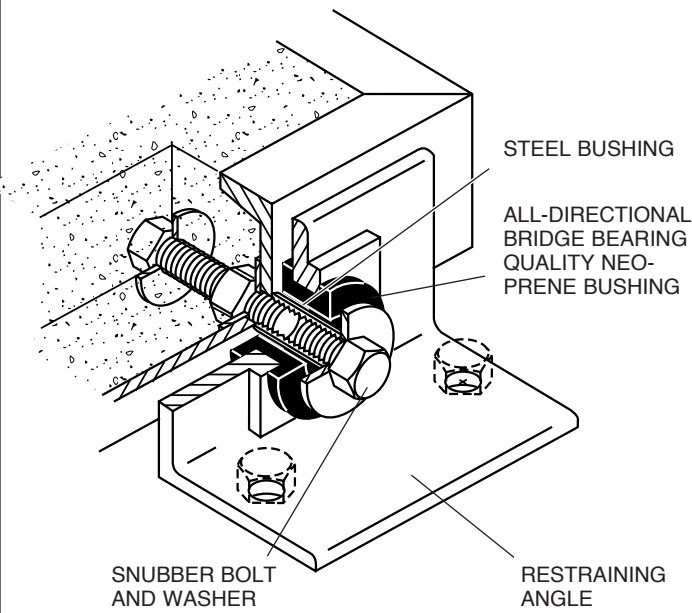

Z-1225 ALL-DIRECTIONAL SEISMIC SNUBBER  
OSHPD PRE-APPROVAL OPA-196

**SPECIFICATION 16**

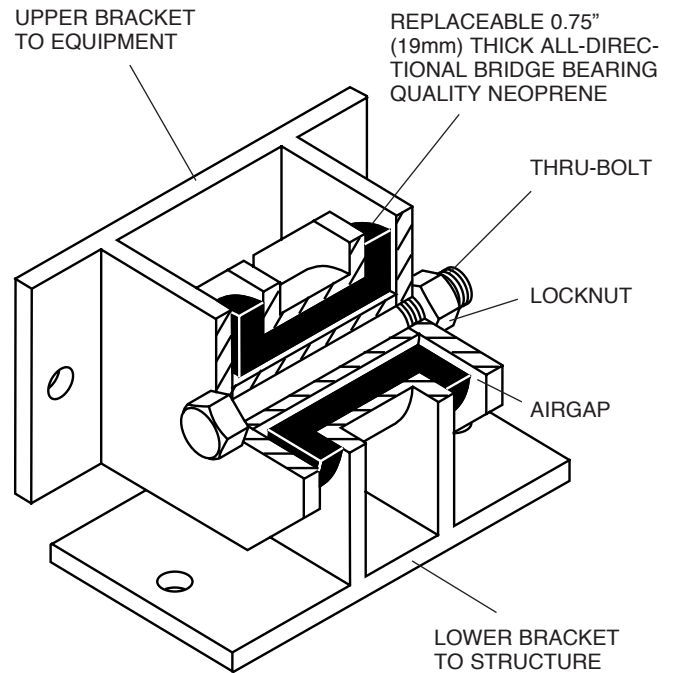

Z-1011 ALL-DIRECTIONAL SEISMIC SNUBBER  
OSHPD PRE-APPROVAL OPA-197

**SPECIFICATION 17**

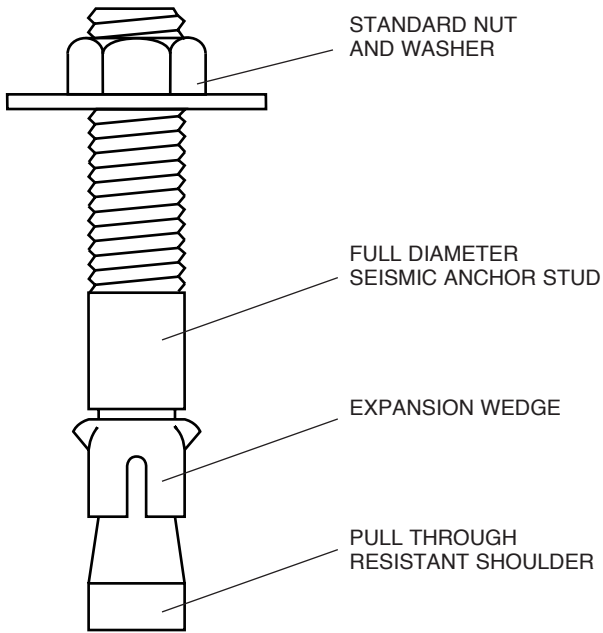

SAS SEISMIC ANCHOR STUD  
ICBO APPROVAL REPORT No. 1821

**SPECIFICATION 18**

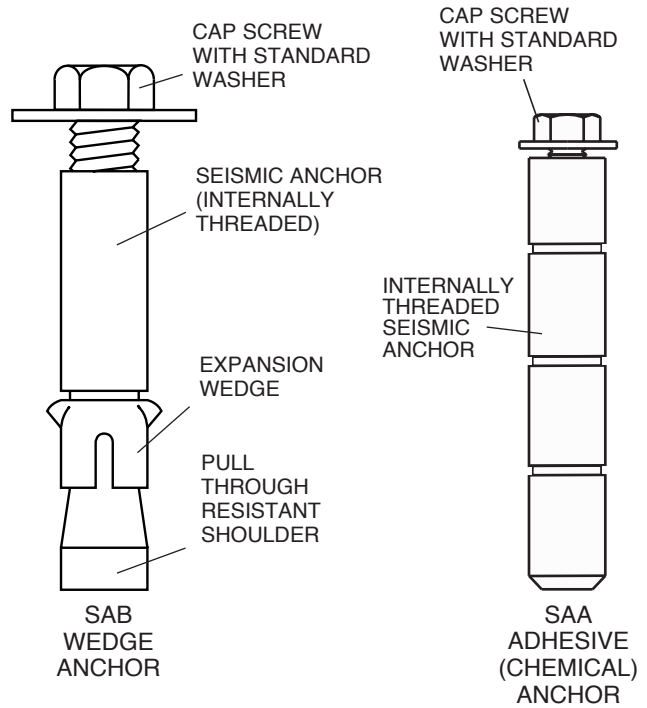

SAB AND SAA SEISMIC ANCHOR BOLTS  
ICBO APPROVAL REPORT No. 5063 & 5000

**SPECIFICATION 19**

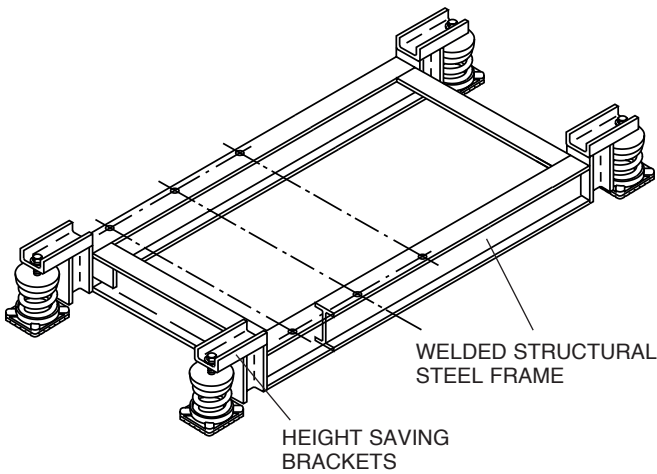

WF WIDE FLANGE STEEL BASE

**SPECIFICATION 20**

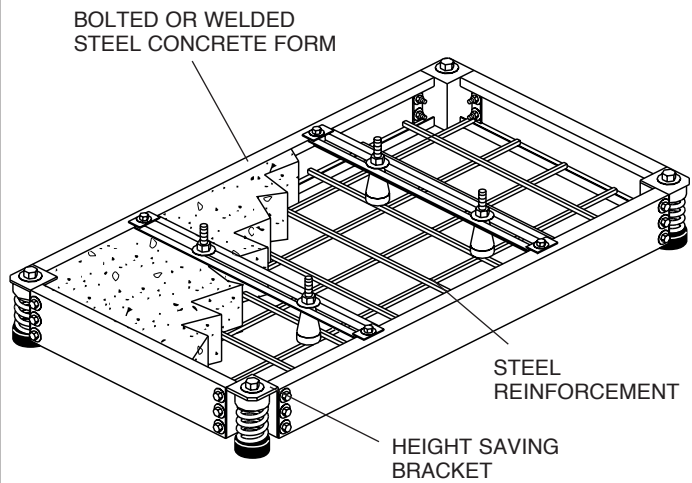

BMK CONCRETE FORM BASE

**SPECIFICATION 21**

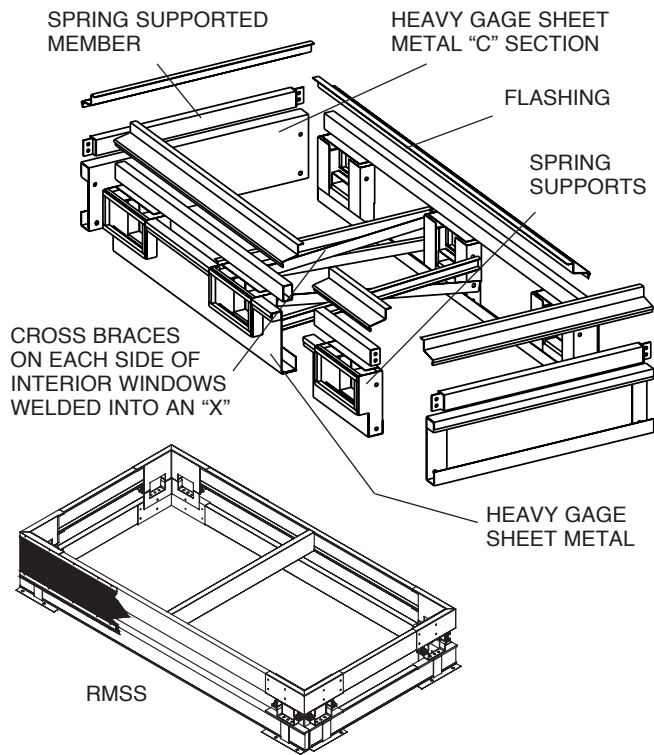

SRSC & RMSS SEISMIC ROOFTOP CURB  
OSHPD PRE-APPROVAL OPA-207

**SPECIFICATION 22**

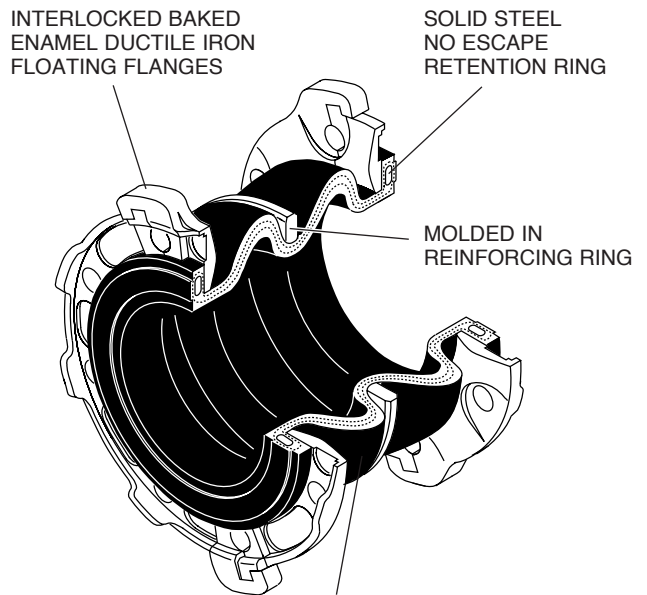

MULTI-LAYERED DUPONT KEVLAR® TIRE CORD FABRIC REINFORCEMENT WITH PEROXIDE CURED DUPONT NORDEL® (EPDM) COVER, LINER AND CORD FRICTIONING

SFDEJ MOLDED EXPANSION JOINT

**SPECIFICATION 23**

RF- END FLANGES ARE PLATE STEEL WITH 150 LB. ASA DRILLING

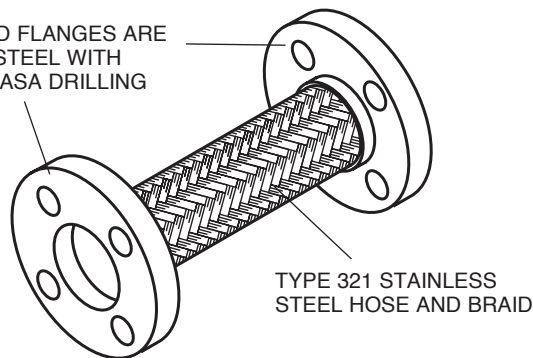

MN- END FITTINGS ARE CARBON STEEL MALE NIPPLES WITH NPT THREADS

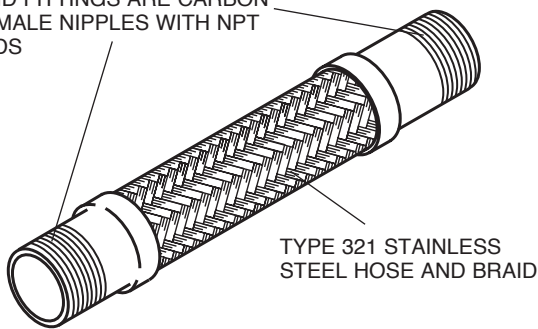

BSSRF and BSSMN STAINLESS STEEL HOSE

**SPECIFICATION 24**

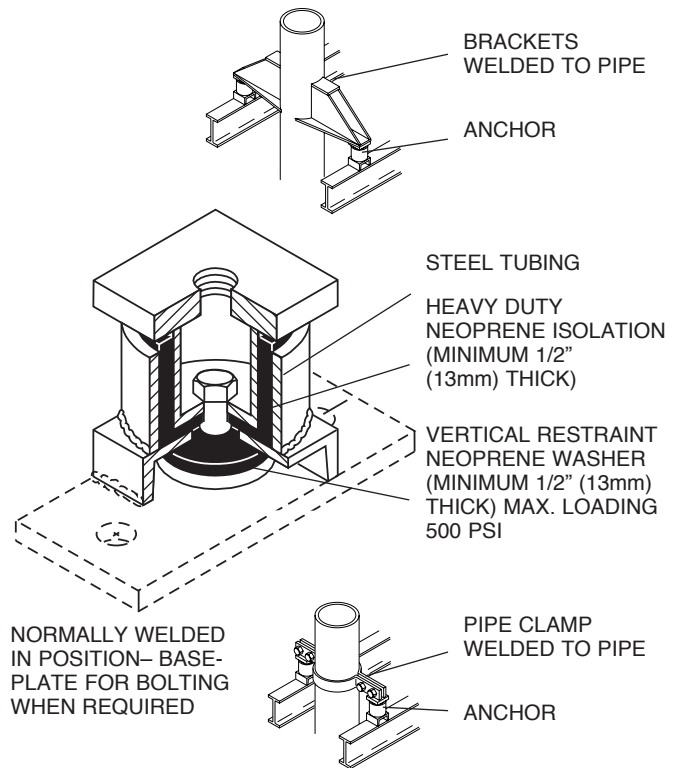

ADA ALL-DIRECTIONAL ANCHOR

**SPECIFICATION 25**

