



# MASON SAFEFLEX

## PEROXIDE CURED EPDM AND DuPONT KEVLAR® TIRE CORD REINFORCEMENT

Safeflex expansion joints are molded and vulcanized in hydraulic presses. This high pressure process produces a smooth finished product with outstanding adhesion between the cover, reinforcement and tube.

Most of our competitors still use Natural Rubber impregnated Nylon tire cord between sulfur cured, EPDM covers and tubes. This construction becomes brittle with age at higher temperatures. We have changed from Nylon to Kevlar®, as Kevlar® has a higher modulus that minimizes swell and elongation, and outstanding temperature tolerance up to 250°F (121°C).

Changing the EPDM curing system from sulfur to the slower, more expensive peroxide method raised the high temperature safety factor, as well as other physical properties. We friction EPDM between and over the Kevlar® cords. This makes Safeflex superior as cover, reinforcement and tube are all homogeneous. Natural Rubber has been completely eliminated to improve aging and temperature tolerance.

Another serious problem was the body pulling out of the flange because flexible bead wire does not provide sufficient retention. Our answer to this was to wrap the tire cord around a solid steel ring in place of the cable. The steel ring cannot pull through.

Sealing pressure is applied through ductile iron flanges that rotate inward around solid exterior stops. The split flanges are hooked together to prevent spreading.

Safeflex is the culmination of 25 years of application experience and a driving desire to eliminate all possible failures. These improvements are costly, but the engineering and contracting communities and the consumers they serve have always been receptive to our improved longer lasting and safer products. Why risk failure when there is a better product.

### SAFEFLEX IS SAFE BECAUSE...

- All Safeflex Expansion Joints are factory tested to 150% of rated pressure before shipment.
- Kevlar® high temperature tolerance is outstanding.
- Peroxide cured EPDM covers, reinforcement rubber and tubes are superior to sulfur cured EPDM and Natural Rubber, Nylon reinforced bodies.
- Kevlar® reinforcement wrapped around solid steel rings cannot pull through the flanges.
- Sealing pressure is higher using external stops as rotation points.

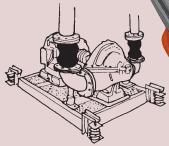

#### SAFEFLEX SFDEJ

SFDEJ double sphere connectors are always our first recommendation. The longer body has better volumetric response to sound pressure waves and provides superior sound attenuation. In seismic zones the extra movement capabilities are very important as well.

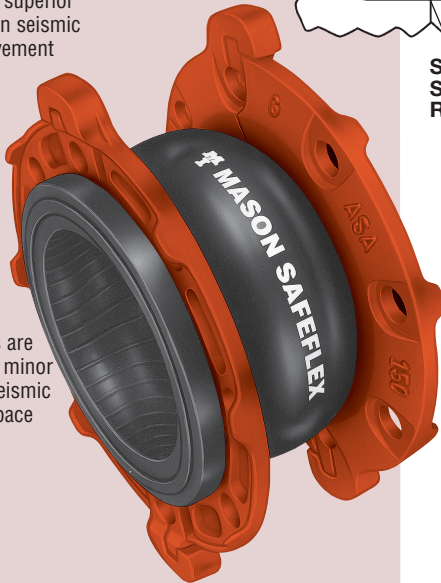
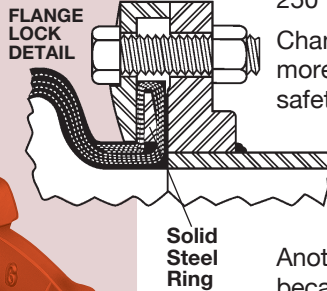

#### SAFEFLEX SFEJ

SFEJ single spheres are used where there is minor expansion and no seismic considerations or space and cost controls.

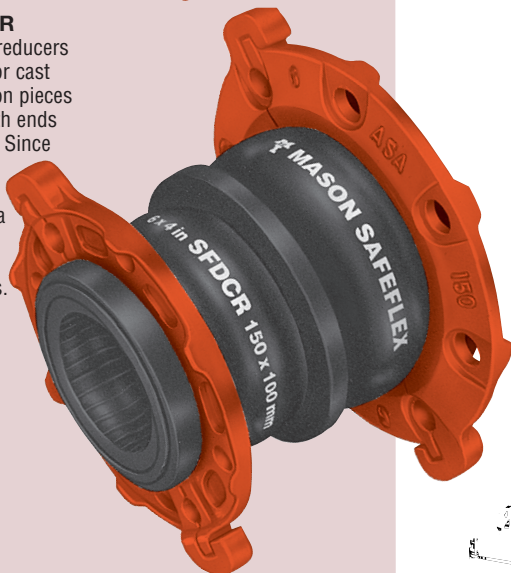

#### SAFEFLEX SFDCR

SFDCR twin sphere reducers eliminate the need for cast iron or steel transition pieces usually found on both ends of pumping systems. Since the reducing fitting is eliminated, there are space, cost and a labor savings. The SFDCR has a wide range of applications.

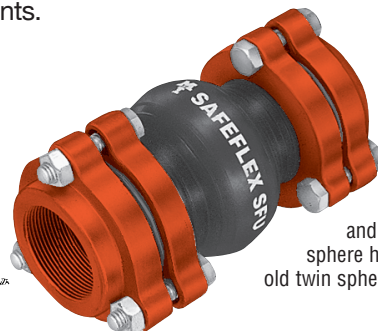

#### SAFEFLEX SFU SINGLE-SPHERE UNION CONNECTOR

SFU single spheres are more than adequate for both acoustics and movements as the new single sphere has similar characteristics to our old twin sphere size 3/4" to 2" (19 to 50mm).

### Single-Sphere SAFEFLEX SFEJ

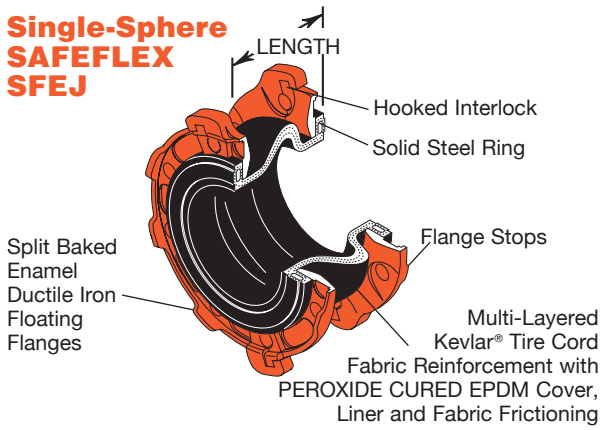

### Twin-Sphere SAFEFLEX SFDEJ

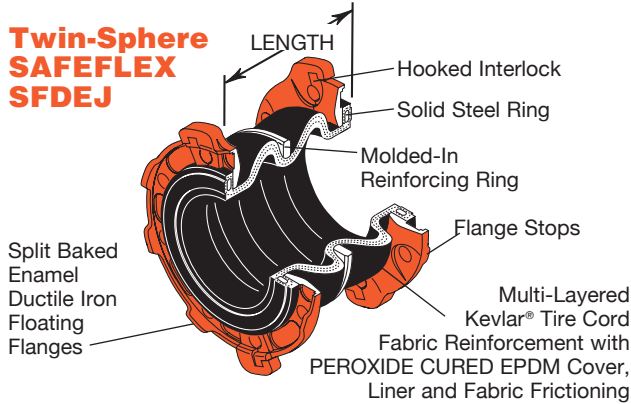

### Single-Sphere SAFEFLEX SFU

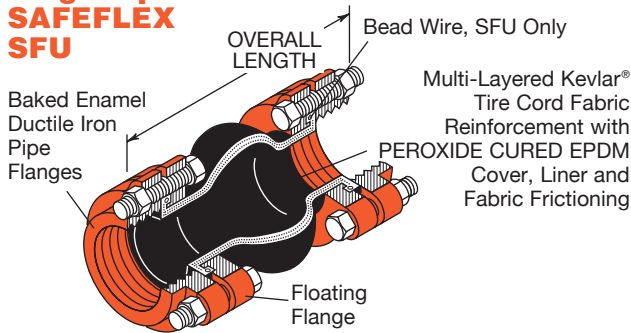

### SAFEFLEX SFU-DI

Ductile Iron Threaded End

### SAFEFLEX SFEJ Dimensions and Allowable Movements

Pipe (in)		Pipe (mm)		Allowable Movements					
Size (in)	Length (in)	Size (mm)	Length (mm)	Angular (degrees)	Compression (in) (mm)	Elongation (in) (mm)	Transverse + (in) + (mm)		
1 1/2		40		21					
2		50		20					
2 1/2	4	65	100	19	5/8 16	1 1/2 12	3/8 9.5		
3		75		18					
4		100		17					
5		125		16					
6		150		15					
8	6	200	150	14	1 25	5/8 16	5/8 16		
10		250		13					
12		300		12					
14		350		10					
16	9	400	225	9	1 1/8 29	7/8 22	7/8 22		
18		450		8					
20		500		7					
24	10	600	250	6	1 1/8 29	1 25	1 25		

### SAFEFLEX SFDEJ Dimensions and Allowable Movements

Pipe (in)		Pipe (mm)		Allowable Movements					
Size (in)	Length (in)	Size (mm)	Length (mm)	Angular (degrees)	Compression (in) (mm)	Elongation (in) (mm)	Transverse + (in) + (mm)		
1 1/2		40		36					
2		50		34					
2 1/2	7	65	175	32	1 1/4 32	3/4 19	3/4 19		
3		75		30					
4		100		28					
5		125		24					
6		150		22					
8	8	200	200	20	1 1/2 38	7/8 22	7/8 22		
10		250		18					
12		300		16					
14	10	350	250	14	1 5/8 41	1 25	1 25		

### SAFEFLEX SFU Dimensions and Allowable Movements

Pipe (in)		Pipe (mm)		Allowable Movements					
Size (in)	Length (in)	Size (mm)	Length (mm)	Angular (degrees)	Compression (in) (mm)	Elongation (in) (mm)	Transverse + (in) + (mm)		
3/4	7	20	175	25					
1	7	25	175	24					
1 1/4	8	32	200	23	3/4 19	3/8 10	3/8 10		
1 1/2	8	40	200	22					
2	8	50	200	21					

### SAFEFLEX SFEJ, SFDEJ, SFDCR and SFU KEVLAR® REINFORCEMENT

Standard and High Pressure Construction-Pressure Reduction at Higher Temperatures

### FITTING OPTIONS



#### SAFEFLEX SFU-SS

Stainless Steel Threaded End



#### SAFEFLEX SFU-CT

Sweat End for Copper Tubing



#### SAFEFLEX SFU-PC

PVC Cement End

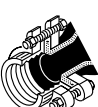

#### SAFEFLEX SFU-PT

PVC Threaded End

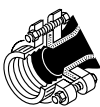

#### SAFEFLEX SFU-BT

Brass Threaded End

Construction Types & Sizes (in) (mm)	Nominal Rating In PSI at:					Nominal Rating In Bar at:					Max. Vacuum	
	170°F	190°F	210°F	230°F	250°F	77°C	88°C	99°C	110°C	121°C	in Hg	Minus Bar
SFEJ Standard 1 1/2" - 16" 40mm - 600mm	250	245	235	225	215	17	16.5	16	15	14	18"	0.6
SFEJ Standard 18" - 24" 450mm - 600mm	180	175	170	165	155	12	11.5	11	10.5	10	18"	0.6
SFDEJ Standard 1 1/2" - 14" 40mm - 350mm	250	245	235	225	215	17	16.5	16	15	14	14"	0.5
SFDCR Standard All Sizes	250	245	235	225	215	17	16.5	16	15	14	14"	0.5
SFU Standard All Sizes	250	245	235	225	215	17	16.5	16	15	14	18"	0.6
SFEJ High Pressure 1 1/2" - 16" 40mm - 400mm	335	325	315	300	285	23	22	21	20	19	29"	1.0
SFEJ High Pressure 18" - 24" 450mm - 600mm	225	220	210	200	190	15	14.5	14	13.5	13	29"	1.0
SFDEJ High Pressure 1 1/2" - 14" 40mm - 350mm	335	325	315	300	285	23	22	21	20	19	22"	0.7

Burst pressures are a minimum of three times Operating Pressures.

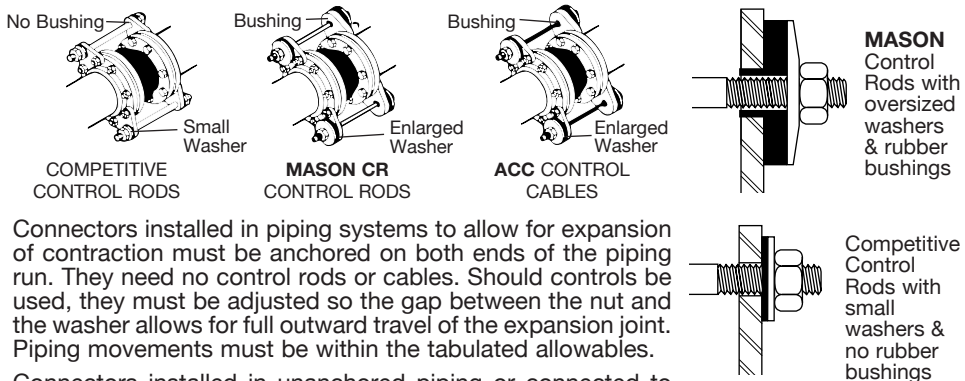

Type CR and ACC control rods and cables are very different than the average rod and rubber washer arrangement. Our sets are all made with oversized washers on the ends to limit the maximum loading on the rubber materials to 1000psi (70kg/cm<sup>2</sup>). Competitive systems use 1/4" (6mm) rubber washers that are the same size as the small standard washers. Thrust forces are so high that standard washers extrude out. In addition to the increased area and thickness of the rubber materials, all our control rod washers are molded with rubber bushings so the rod or cable cannot contact the steel restraining plates and short circuit the system acoustically.

Connectors installed in piping systems to allow for expansion of contraction must be anchored on both ends of the piping run. They need no control rods or cables. Should controls be used, they must be adjusted so the gap between the nut and the washer allows for full outward travel of the expansion joint. Piping movements must be within the tabulated allowables.

Connectors installed in unanchored piping or connected to isolated equipment only require control rods or cables for pressures as tabulated if as noted in lower righthand table.

## Installation Instructions for Safeflex SFEJ & SFDEJ

**Install only where leakage or failure will not result in injury or property damage.**

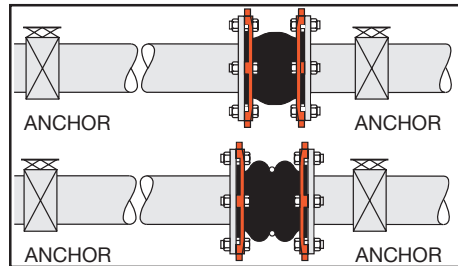

SFEJ AND SFDEJ CONNECTORS THAT ARE USED IN EXPANSION APPLICATIONS MUST BE INSTALLED WITH ANCHORS ON EITHER SIDE OF THE CONNECTOR.

SFEJ AND SFDEJ CONNECTORS USED AS NOISE AND VIBRATION DAMPENERS ONLY AND INSTALLED IN UNANCHORED PIPING WILL GROW IN RESPONSE TO THE PRESSURE AS SHOWN BELOW. Adjust the spring mountings so the equipment is at the proper level. Leave a space between pipe flanges equal to the length shown below and draw the connectors out evenly with the flange bolts. Spring supported equipment may lift in response to the tightening so the connector may not be fully extended. When the connector is at operating pressure the system will return to the original position.

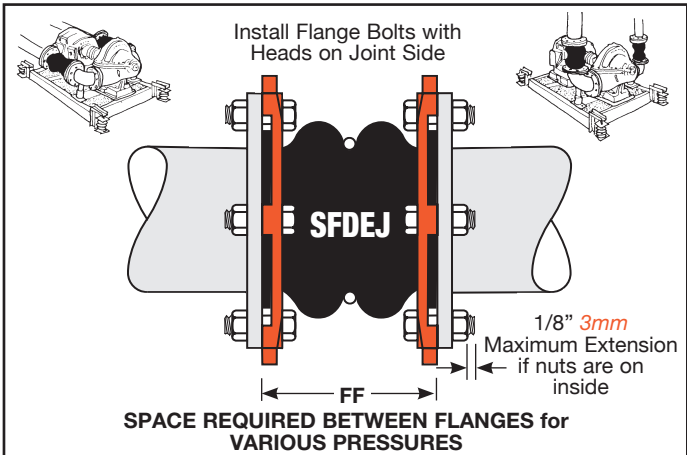
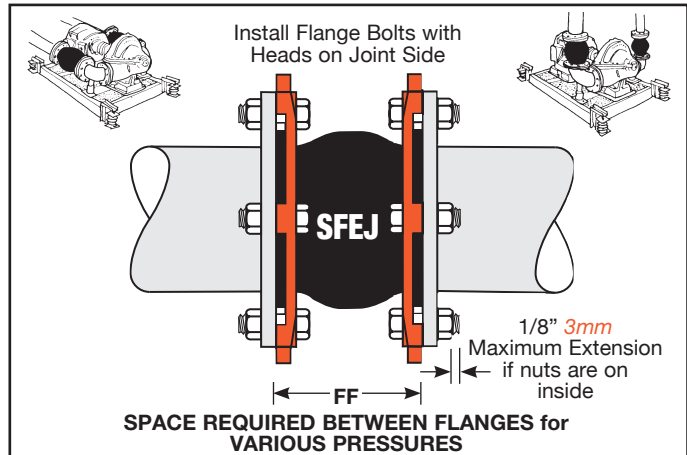

**SAFEFLEX SFEJ Pressure Extension Table**

Pipe Size (in)	250 lb. Construction				Pipe Size (mm)	17 Bar Construction			
	0 psi	100 psi	200 psi	250 psi		0 Bar	6.8 Bar	13.6 Bar	17 Bar
	Face to Face Length (in)					Face to Face Length (mm)			
1 1/2	4	4	4	4	40	100	100	100	100
2	4	4	4	4	50	100	100	100	100
2 1/2	4	4	4	4	60	100	100	100	100
3	4	4	4	4	75	100	100	100	100
4	4	4 1/4	4 3/8	4 3/8	100	100	106	110	110
5	4	4 1/4	4 3/8	4 3/8	125	100	106	110	110
6	6	6 1/4	6 3/8	6 3/8	150	150	156	160	160
8	6	6 1/4	6 3/8	6 3/8	200	150	156	160	160
10	6	6 1/4	6 3/8	6 3/8	250	150	156	160	160
12	6	6 3/8	6 1/2	6 1/2	300	150	160	163	163
14	9	9 1/4	9 3/8	9 1/2	350	225	231	235	238
16	9	9 1/2	9 3/4	9 7/8	400	225	238	244	247
Pipe Size (in)	180 lb. Construction				Pipe Size (mm)	12.25 Bar Construction			
	0 psi	100 psi	150 psi	180 psi		0 Bar	6.8 Bar	10.2 Bar	12.2 Bar
	Face to Face Length (in)					Face to Face Length (mm)			
18	9	9 5/8	9 3/4	9 7/8	450	225	241	244	247
20	9	9 5/8	9 3/4	9 7/8	500	225	241	244	247
24	10	10 5/8	10 7/8	11	600	250	266	269	275

**SAFEFLEX SFDEJ Pressure Extension Table**

Pipe Size (in)	250 lb. Construction				Pipe Size (mm)	17 Bar Construction			
	0 psi	100 psi	200 psi	250 psi		0 Bar	6.8 Bar	13.6 Bar	17 Bar
	Face to Face Length (in)					Face to Face Length (mm)			
1 1/2	7	7	7	7	40	175	175	175	175
2	7	7	7	7	50	175	175	175	175
2 1/2	7	7	7	7	60	175	175	175	175
3	7	7 1/8	7 3/16	7 1/4	75	175	178	180	181
4	7	7 1/8	7 3/16	7 1/4	100	175	178	180	181
5	7	7 1/8	7 1/4	7 3/8	125	175	178	181	185
6	7	7 3/16	7 3/8	7 1/2	150	175	180	185	188
8	8	8 3/16	8 3/8	8 1/2	200	200	205	210	213
10	8	8 1/4	8 1/2	8 5/8	250	200	206	213	216
12	8	8 1/4	8 1/2	8 5/8	300	200	206	213	216
14	10	10 1/4	10 1/2	10 5/8	350	250	256	263	256

**CAUTION:** This extension procedure is an **ABSOLUTE** must on all connections to spring mounted systems such as pumps (when control rods are not used) or the connections may drive the spring solid under the pumps or shift the foundation.

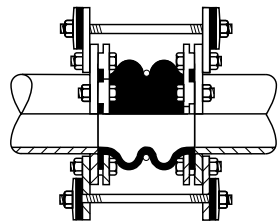

- Only Use Control Rods or Cables if:**
1. Expansion Joints cannot be pre-extended and pipe or equipment would be a problem.
  2. As an added precaution.

All high pressure connectors should have control rods set at maximum expansion joint allowable elongation.

## SAFLEX SFD CR

Interlocked Baked Enamel Ductile Iron Floating Flanges

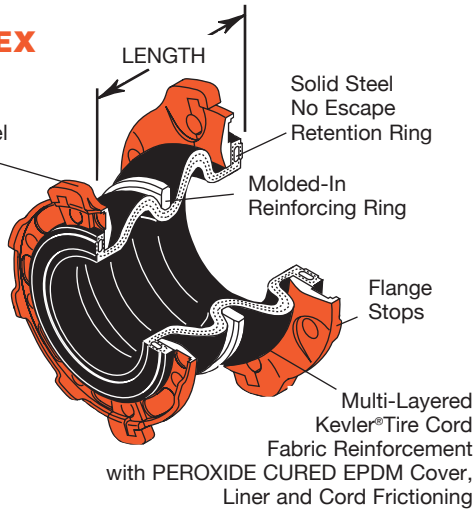

## SAFLEX SFD CR Dimensions and Allowable Movements

Pipe (in)		Pipe (mm)		Allowable Movements						
Size	Length (in)	Size	Length (mm)	Angular (degrees)	Compression (in)	Elongation (mm)	(in)	(mm)	Transverse ±(in)	±(mm)
3x2	6	75x50	150	25	1	25	5/8	16	5/8	16
3x2 1/2	6	75x60	150							
4x3	7	100x75	175	20	1 1/4	32	3/4	19	3/4	19
5x4	8	125x100	200							
6x4	9	150x100	225	15	15/8	41	3/4	19	7/8	22
6x5	9	150x125	225							
8x6	11	200x150	275							
10x8	12	250x200	300							

## SAFLEX SFD CR

Pressure Extension Table 250 lb 17 Bar Construction

Pipe Size (in)	0	100	200	250	Pipe Size (mm)	0	6.8	13.6	17
	psi	psi	psi	psi		Bar	Bar	Bar	Bar
Face to Face Length					Face to Face Length				
3x2	6	61/8	63/16	61/4	75x50	150	153	155	156
3x2 1/2	6	61/8	63/16	61/4	75x60	150	153	155	156
4x3	7	71/8	71/4	73/8	100x75	175	178	181	185
5x4	8	83/16	83/8	81/2	125x100	200	205	210	212
6x4	9	93/16	93/8	91/2	150x100	225	230	235	237
6x5	9	93/4	97/16	99/16	150x125	225	231	236	239
8x6	11	113/8	111/2	115/8	200x150	275	285	287	291
10x8	12	121/2	123/4	13	250x200	300	312	319	325

All flanged expansion joints illustrated in this bulletin are available with:

- 150 lb ASA Drilling
- 300 lb ASA Drilling
- BRITISH Series E Drilling
- BRITISH Series F Drilling
- DIN or PIN-10
- DIN or PIN-16
- DIN or PIN-25

## Installation Procedures for Saflex SFEJ, SFDEJ, SFD CR and SFU

It is our general recommendation that flexible connectors are always installed on the equipment side of the shut-off valve, and they are not used in pipe lines that pass through finished ceilings where water damage to the structure or the equipment below can be extensive.

**Install only where leakage or failure will not result in injury or property damage.**

1. a. Expansion joint rubber flanges must be in contact with a flat surface. Normal 1/16" raised face is o.k. Unacceptable depressions or protrusions are typical of victaulic or similar flanges.
- b. Flange stops must bear on full diameter mating flanges.
- c. Rubber flanges will not retain loose elements in valve bodies that rely on contact with a steel flange. For example, some check valves are manufactured with brass inserts positioned by screws. When mating steel flanges with these valves, there is no problem. However, with a rubber connector, it cuts the rubber face and can cause failure, leakage or brass insert escape.
2. Any of the above conditions must be corrected by installing a full diameter steel flange drilled to standard dimensions so the flange bolts pass through it. The I.D. matches the I.D. of the piping. Minimum Plate Thickness is as follows: 1/2" thick for 1-1/2" to 8" pipe, 3/4" thick for 10" to 18" pipe, and 1" thick for 20" to 24" pipe. Gasket between this filler flange and the mating steel flange.
3. Before installing the connector be certain that all surfaces are clean and there are no sharp edges of any kind on the steel flanges. No gasket is required. Apply a thin film of graphite dispersed in glycerin or water to the face of the rubber flanges before installing. No other type of lubricant or seal should be used on the flange face. The graphite prevents the rubber from adhering to the metal flange so that the rubber joint can be removed without damage, should it ever be necessary.
4. If the connector is to be installed in a system where the operating pressures do not dictate the use of control rods, but the connector is to be pre-extended to allow for growth under pressure, the gap between the piping flanges should be large enough to allow for the growth as indicated on the operating pressure chart.
5. Expansion joints installed for expansion and compression applications should be installed at normal length. Check allowable movements against design requirements between anchors.
6. Check temperature and pressure ratings and never exceed them.
7. Check for chemical compatibility with the ordered material.
8. Do not weld near the expansion joints or weld the steel flanges to the piping after the expansion joints are installed. This will either burn or seriously damage the expansion joints.
9. Although the expansion joints will readily adjust themselves to mis-aligned flanges within the specified movements, they should not be installed where there is more than 1/8" of initial misalignment or lack of parallelism in the expansion joints.
10. Slide the connector into position and insert all the flange bolts. The rubber face must be centered exactly on the opening. Be sure that the bolts are inserted with the heads facing the rubber and the nuts on the outside so they are on the outside of the mating flange. If it is impossible to insert the bolts in this direction, the tightened end of the bolt must not protrude more than 1/8" beyond the inside nut. Larger protrusions may result in the bolt cutting into the rubber cover.
11. After all bolts are inserted, make them finger tight and then proceed to adjust them evenly in a circle. Tighten the bolts to 60% of the maximum recommended torque for the bolt size until all bolts have the same tightness. Tightness may be increased if there is joint leakage.
12. All rubber materials tend to relax over a period of time. It is good practice to check the tightness of the bolts for the 60% torque about two weeks after installation, and in extreme cases, particularly when a line is heated up and allowed to cool repeatedly it is advisable to continue to check bolt tightness on a monthly basis until such time as the last check shows no further tightening is required.
13. Allowing the bolts to loosen may cause leaks.
14. Insulation on cold lines should be installed for easy removal to facilitate retightening.
15. In order to prevent heat buildup, expansion joints in hot lines should not be insulated.
16. While our expansion joints are guaranteed for a period of one year and designed for many years of service, it is suggested that expansion joints are replaced every five years. Cover cracking is of no significance and only cosmetic.

### SFU Installation Instructions (See general precautions above)

1. Attach flanges to piping so length between inside flange faces is equal to face to face length of rubber section of the SFU.
2. Insert center section of the SFU and the 3 bolts on each end. Tighten evenly to 60% of torque value.
3. Retighten as in 12 above.

**IT IS IMPORTANT TO FOLLOW ALL OF THE NUMBERED INSTRUCTIONS TO AVOID NEEDLESS PROBLEMS.**



**MASON INDUSTRIES, Inc.**

350 Rabro Drive, Hauppauge, NY 11788 • Reply to: PO Box 410, Smithtown, NY 11787  
631/348-0282 • FAX 631/348-0279 • Web: www.mason-ind.com • E-mail: Info@Mason-ind.com